

UNIT – I

STRESS, STRAIN AND DEFORMATION OF SOLIDS

TYPES OF STRESSES :

Only two basic stresses exist : (1) normal stress and (2) shear stress. Other stresses either are similar to these basic stresses or are a combination of these e.g. bending stress is a combination of tensile, compressive and shear stresses. Torsional stress, as encountered in twisting of a shaft is a shearing stress.

Let us define the normal stresses and shear stresses in the following sections.

Normal stresses : We have defined stress as force per unit area. If the stresses are normal to the areas concerned, then these are termed as normal stresses. The normal stresses are generally denoted by a Greek letter (σ)

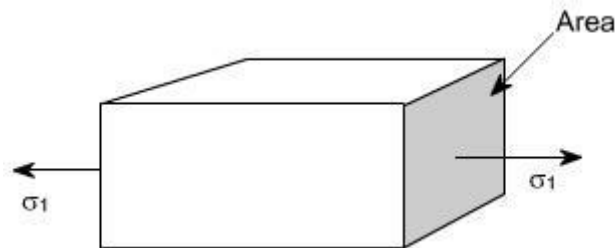

This is also known as uniaxial state of stress, because the stresses act only in one direction however, such a state rarely exists, therefore we have biaxial and triaxial state of stresses where either the two mutually perpendicular normal stresses act or three mutually perpendicular normal stresses act as shown in the figures below :

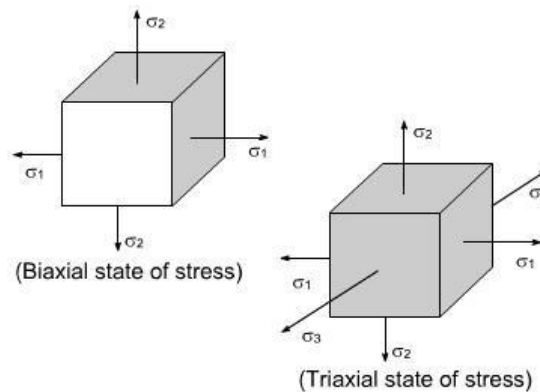

Tensile or compressive stresses :

The normal stresses can be either tensile or compressive whether the stresses act out of the area or into the area

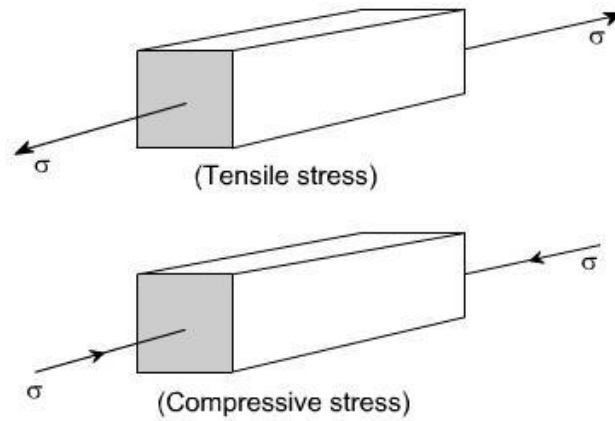

Shear stresses :

Let us consider now the situation, where the cross – sectional area of a block of material is subject to a distribution of forces which are parallel, rather than normal, to the area concerned. Such forces are associated with a shearing of the material, and are referred to as shear forces. The resulting force intensities are known as shear stresses.

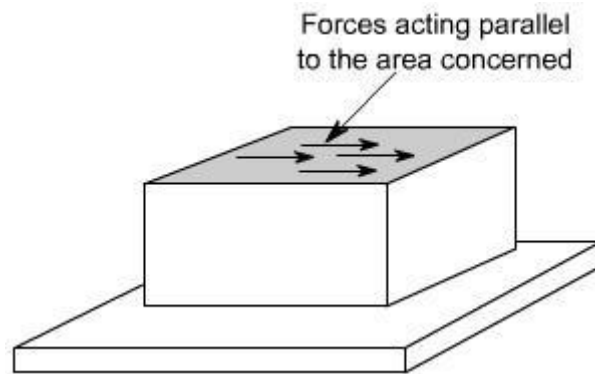

The resulting force intensities are known as shear stresses, the mean shear stress being equal to

$$\tau = \frac{P}{A}$$

Where P is the total force and A the area over which it acts.

As we know that the particular stress generally holds good only at a point therefore we can define shear stress at a point as

$$\tau = \lim_{\delta A \rightarrow 0} \frac{\delta F}{\delta A}$$

The greek symbol τ (tau) (suggesting tangential) is used to denote shear stress.

However, it must be borne in mind that the stress (resultant stress) at any point in a body is basically resolved into two components and one acts perpendicular and other parallel to the area concerned, as it is clearly defined in the following figure.

Shear failure of Rivets

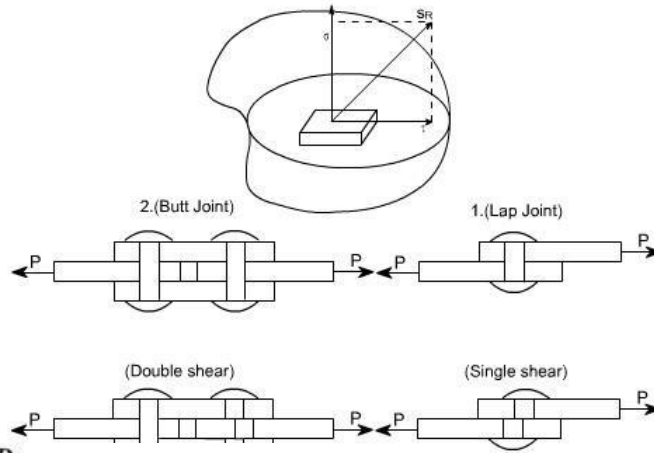

Stress at section CD:

The rivet area is 1.51 cm². Find the extension of the bar.

$$\text{Stress, } \sigma_{CD} = \frac{\text{Load}}{\text{Area}} = \frac{P}{\frac{\pi}{4} (D_3)^2}$$

$$= \frac{40,000}{\frac{\pi}{4} (50)^2} = 20.37 \text{ N/mm}^2$$

$$\sigma_{CD} = 20.37 \text{ N/mm}^2$$

We know that,

Given Total elongation, $\delta L = \frac{P}{E} \left[\frac{L_1}{A_1} + \frac{L_2}{A_2} + \frac{L_3}{A_3} \right] = 50$

$L_1 = 300 \text{ mm}; L_2 = 250 \text{ mm}; L_3 = 200 \text{ mm}$

$E = 2 \times 10^5 \text{ N/mm}^2$

ie and the shear area is the cross - sectional of the rivet in the case of Butt joints of rivetts and the shear area is the cross-sectional of the rivet.

As shown in Fig. and (ii) find the total extension of the bar.

05 To find: (1) Stresses in each section, and (2) Total extension of the bar.

☺ Solution: Stress at section AB:

$$\text{Stress, } \sigma_{AB} = \frac{\text{Load}}{\text{Area}} = \frac{P}{\frac{\pi}{4} (D_1)^2} = \frac{40,000}{\frac{\pi}{4} (20)^2} = 127.32 \text{ N/mm}^2$$

Stress at section BC:

$$\text{Stress, } \sigma_{BC} = \frac{\text{Load}}{\text{Area}} = \frac{P}{\frac{\pi}{4} (D_2)^2} = \frac{40,000}{\frac{\pi}{4} (40)^2} = 31.83 \text{ N/mm}^2$$

$$\sigma_{BC} = 31.83 \text{ N/mm}^2$$

Result: $\sigma_{AB} = 127.38 \text{ N/mm}^2$

$\sigma_{BC} = 31.8 \text{ N/mm}^2$

$\sigma_{CD} = 20.38 \text{ N/mm}^2$

$\delta L = 0.25 \text{ mm}$

$$= 0.2 \left[\frac{300}{\frac{\pi}{4} (D_1)^2} + \frac{250}{\frac{\pi}{4} (D_2)^2} + \frac{200}{\frac{\pi}{4} (D_3)^2} \right]$$

$$= 0.2 \left[\frac{300}{\frac{\pi}{4} (20)^2} + \frac{250}{\frac{\pi}{4} (40)^2} + \frac{200}{\frac{\pi}{4} (50)^2} \right]$$

$$= 0.2 [0.955 + 0.199 + 0.101]$$

Change in length, $\delta L = 0.25 \text{ mm}$

2. A member ABCD is subjected to point loads P_1, P_2, P_3, P_4 as shown in fig. Calculate the force P_2 necessary for equilibrium, if $P_1 = 45 \text{ kN}$, $P_3 = 450 \text{ kN}$ and $P_4 = 139 \text{ kN}$. Determine the total elongation of the member, assuming the modulus of elasticity to be $2.1 \times 10^5 \text{ N/mm}^2$

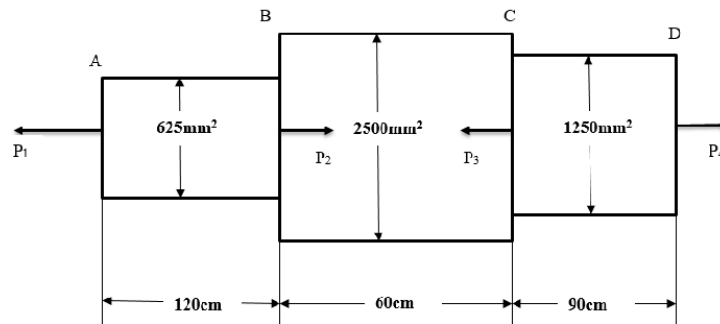

Sol. Given :

Part AB :	Area,	$A_1 = 625 \text{ mm}^2$ and
	Length,	$L_1 = 120 \text{ cm} = 1200 \text{ mm}$
Part BC :	Area,	$A_2 = 2500 \text{ mm}^2$ and
	Length,	$L_2 = 60 \text{ cm} = 600 \text{ mm}$
Part CD :	Area,	$A_3 = 1250 \text{ mm}^2$ and
	Length,	$L_3 = 90 \text{ cm} = 900 \text{ mm}$
Value of		$E = 2.1 \times 10^5 \text{ N/mm}^2$.

Value of P_2 necessary for equilibrium

Resolving the forces on the rod along its axis (*i.e.*, equating the forces acting towards right to those acting towards left), we get

$$P_1 + P_3 = P_2 + P_4$$

\therefore Increase in length of AB

$$= \frac{P}{A_1 E} \times L_1 = \frac{45000}{625 \times 2.1 \times 10^5} \times 1200 \quad (\because P = 45 \text{ kN} = 45000 \text{ N})$$

$$= 0.4114 \text{ mm}$$

Decrease in length of BC

$$= \frac{P}{A_2 E} \times L_2 = \frac{320,000}{2500 \times 2.1 \times 10^5} \times 600 \quad (\because P = 320 \text{ kN} = 320000)$$

$$= 0.3657 \text{ mm}$$

Increase in length of CD

$$= \frac{P}{A_3 E} \times L_3 = \frac{130,000}{1250 \times 2.1 \times 10^5} \times 900 \quad (\because P = 130 \text{ kN} = 130000)$$

$$= 0.4457 \text{ mm}$$

Total change in the length of member

$$= 0.4114 - 0.3657 + 0.4457$$

(Taking +ve sign for increase in length and
-ve sign for decrease in length)

$$= 0.4914 \text{ mm (extension). Ans.}$$

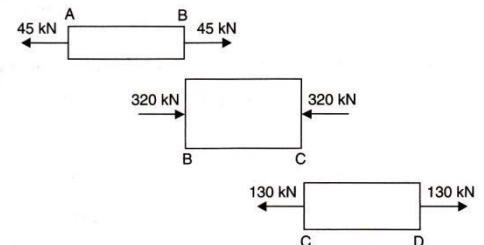

$$\delta l = 0.4914 \text{ mm}$$

Thermal stresses, Bars subjected to tension and Compression

Compound bar: In certain application it is necessary to use a combination of elements or bars made from different materials, each material performing a different function. In over head electric cables or Transmission Lines for example it is often convenient to carry the current in a set of copper wires surrounding steel wires. The later being designed to support the weight of the cable over large spans. Such a combination of materials is generally termed compound bars.

Consider therefore, a compound bar consisting of n members, each having a different length and cross sectional area and each being of a different material. Let all member have a common extension 'x' i.e. the load is positioned to produce the same extension in each member.

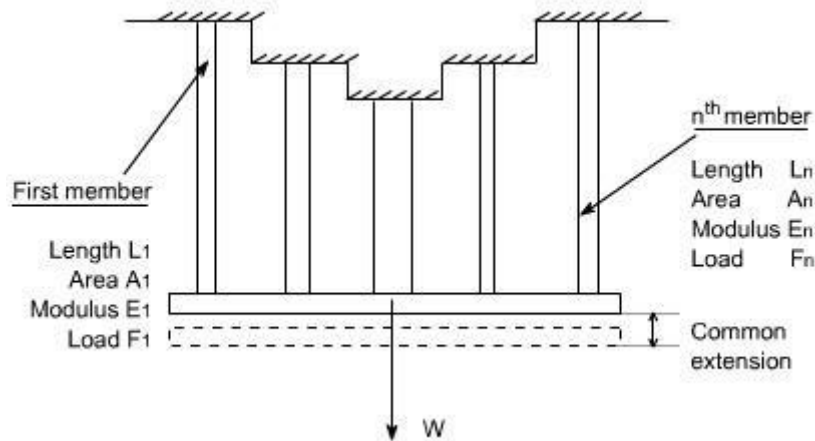

For the 'n' the members

$$\frac{\text{stress}}{\text{strain}} = E_n = \frac{F_n / A_n}{x_n / L_n}$$

$$= \frac{F_n \cdot L_n}{A_n \cdot x_n}$$

or $F_n = \frac{E_n \cdot A_n \cdot x_n}{L_n} = \frac{E_n \cdot A_n \cdot x}{L_n} \dots (1)$

Where F_n is the force in the nth member and A_n and L_n are its cross - sectional area and length.

Let W be the total load, the total load carried will be the sum of all loads for all the members.

Therefore, each member carries a portion of the total load W proportional of EA / L value.

if the length of each individual member in same then, we may write $F_1 = \frac{E_1 \cdot A_1}{\sum E \cdot A} \cdot W$

Thus, the stress in member '1' may be determined as $\sigma_1 = F_1 / A_1$

Determination of common extension of compound bars: In order to determine the common extension of a compound bar it is convenient to consider it as a single bar of an imaginary material with an equivalent or combined modulus E_c .

Assumption: Here it is necessary to assume that both the extension and original lengths of the individual members of the compound bar are the same, the strains in all members will than be equal.

Total load on compound bar = $F_1 + F_2 + F_3 + \dots + F_n$

where F_1, F_2, \dots , etc are the loads in members 1,2 etc

But force = stress . area, therefore

$s(A_1 + A_2 + \dots + A_n) = s_1 A_1 + s_2 A_2 + \dots + s_n A_n$

Where s is the stress in the equivalent single bar

Dividing throughout by the common strain \hat{I} .

$$\frac{\sigma}{\epsilon}(A_1 + A_2 + \dots + A_n) = \frac{\sigma_1}{\epsilon}A_1 + \frac{\sigma_2}{\epsilon}A_2 + \dots + \frac{\sigma_n}{\epsilon}A_n$$

i.e $E_c(A_1 + A_2 + \dots + A_n) = E_1A_1 + E_2A_2 + \dots + E_nA_n$

or $E_c = \frac{E_1A_1 + E_2A_2 + \dots + E_nA_n}{A_1 + A_2 + \dots + A_n}$

or $E_c = \frac{\sum EA}{\sum A}$

with an external load W applied stress in the equivalent bar may be computed as

$$\text{stress} = \frac{W}{\sum A}$$

$$\text{strain in the equivalent bar} = \frac{x}{L} = \frac{W}{\sum A E_c}$$

$$\text{hence common extension } x = \frac{WL}{E_c \sum A}$$

1. A Mild steel rod of 20 mm diameter and 300 mm long is enclosed centrally inside a hollow copper tube of external diameter 30 mm and internal diameter 25 mm. The ends of the rod and tube are brazed together, and the composite bar is subjected to an axial pull of 40 kN. If E for steel and copper is 200 GN/m² and 100 GN/m² respectively, find the stresses developed in the rod and the tube also find the extension of the rod.

GIVEN DATA

Dia of steel rod = 20 mm

$$\text{Area of steel rod} = A_s = \frac{\pi}{4} \times 20^2 = 100\pi \text{ mm}^2$$

$$\text{Area of Copper tube} = A_c = \frac{\pi}{4} \times (30^2 - 25^2) = 215.98 \text{ mm}^2$$

$$E_s = 200 \text{ GN/m}^2 = 200 \times 10^3 \text{ N/mm}^2 ; E_c = 100 \text{ GN/m}^2 = 100 \times 10^3 \text{ N/mm}^2$$

TO FIND

Stresses on the tube and rod

Solution

$$\frac{\sigma_s}{E_s} = \frac{\sigma_c}{E_c} ; \sigma_s = \frac{E_s}{E_c} \times \sigma_c ; \sigma_s = 2\sigma_c$$

$$E_s \quad E_c \quad E_c$$

$$P = P_s + P_c$$

$$50 \times 10^3 = \sigma_s A_s + \sigma_c A_c$$

$$50 \times 10^3 = 2\sigma_c \cdot 100\pi + \sigma_c \cdot 215.98$$

$$\sigma_c = 59.21 \text{ N/mm}^2$$

$$\sigma_s = 118.45 \text{ N} / \text{mm}^2$$

2. A reinforced concrete column 50cm x 50cm in section is reinforced with 4 steel bars of 2.5cm diameter, one in each corner. The column is carrying a load of 2 MN. Find the stresses in the concrete and steel bars.

Take,

Modulus of Elasticity for steel $E_s = 2.1 \times 10^5 \text{ N/mm}^2$

Modulus of Elasticity for concrete $E_c = 1.4 \times 10^4 \text{ N/mm}^2$

Given:

Concrete column dimensions = 50 cm x 50 cm
= 500 mm x 500 mm

Diameter of steel bar, $D_s = 2.5 \text{ cm} = 25 \text{ mm}$

Load, $P = 2 \text{ MN} = 2 \times 10^6 \text{ N}$

$E_s = 2.1 \times 10^5 \text{ N/mm}^2$

$E_c = 1.4 \times 10^4 \text{ N/mm}^2$

To find: Stresses in the concrete and steel bars.

☺ Solution: Area of column = 500 mm x 500 mm

$$= 25 \times 10^4 \text{ mm}^2$$

$$= 2500 \text{ cm}^2$$

$$\boxed{\text{Area of column} = 25 \times 10^4 \text{ mm}^2}$$



$$\text{Area of steel, } A_s = \frac{\pi}{4} \times (25)^2$$

$$= 4.90 \times 10^2 \text{ mm}^2$$

For four steel bar, $A_s = 4 \times 4.90 \times 10^2 \text{ mm}^2$

$$= 1963.4 \text{ mm}^2$$

$$\boxed{\text{Area of steel, } A_s = 1963.4 \text{ mm}^2}$$

∴ Area of concrete = Area of column – Area of steel

$$= 250000 - 1963.4$$

$$\boxed{\text{Area of concrete, } A_c = 2,48,036.6 \text{ mm}^2}$$

We know that,

Total load, $P = \text{Load on steel bar} + \text{Load on concrete}$

$$2 \text{ MN} = P_s + P_c$$

$$\boxed{2 \times 10^6 = P_s + P_c} \quad \dots (A)$$

We know that,

Change in length of steel bar = Change in length of concrete

$$\Rightarrow \frac{P_s L_s}{A_s E_s} = \frac{P_c L_c}{A_c E_c}$$

The length of steel bar and concrete are equal.

$$\text{So, } L_s = L_c$$

$$\Rightarrow \frac{P_s}{A_s E_s} = \frac{P_c}{A_c E_c}$$

$$\Rightarrow \frac{P_s}{1963.4 \times 2.1 \times 10^5} = \frac{P_c}{248036.6 \times 1.4 \times 10^4}$$

$$\boxed{P_s = 0.118 P_c}$$

Substituting in (A),

$$(A) \Rightarrow 2 \times 10^6 = P_s + P_c$$

$$2 \times 10^6 = 0.118 P_c + P_c$$

$$P_c = 1.78 \times 10^6 \text{ N}$$

$$\Rightarrow P_s = (0.118) \times 1.78 \times 10^6$$

$$P_s = 0.21 \times 10^6 \text{ N}$$

$$\text{Stress on steel bar, } \sigma_s = \frac{\text{Load}}{\text{Area}} = \frac{P_s}{A_s} = \frac{0.21 \times 10^6}{1963.4}$$

$$\text{Stress on steel bar, } \sigma_s = 106.96 \text{ N/mm}^2$$

$$\text{Stress on concrete, } \sigma_c = \frac{\text{Load}}{\text{Area}} = \frac{P_c}{A_c} = \frac{1.78 \times 10^6}{248036.6}$$

$$\text{Stress on concrete, } \sigma_c = 7.18 \text{ N/mm}^2$$

Result: Stress on steel bar, $\sigma_s = 106.96 \text{ N/mm}^2$

Stress on concrete, $\sigma_c = 7.18 \text{ N/mm}^2$

Compound bars subjected to Temp. Change : Ordinary materials expand when heated and contract when cooled, hence , an increase in temperature produce a positive thermal strain. Thermal strains usually are reversible in a sense that the member returns to its original shape when the temperature return to its original value. However, there here are some materials which do not behave in this manner. These metals differs from ordinary materials in a sence that the strains are related non linearly to temperature and some times are irreversible .when a material is subjected to a change in temp. is a length will change by an amount.

$$d_t = a .L.t$$

$$\text{or } \hat{I}_t = a .L.t \text{ or } s_t = E .a.t$$

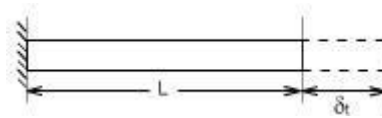

a = coefficient of linear expansoin for the material

L = original Length t = temp. change

Thus an increase in temperature produces an increase in length and a decrease in temperature results in a decrease in length except in very special cases of materials with zero or negative coefficients of expansion which need not to be considered here.

If however, the free expansion of the material is prevented by some external force, then a stress is set up in the material. They stress is equal in magnitude to that which would be produced in the bar by initially allowing the bar to its free length and then applying sufficient force to return the bar to its original length.

$$\text{Change in Length} = a L t$$

$$\text{Therefore, strain} = a L t / L$$

$$= a t$$

Therefore, the stress generated in the material by the application of sufficient force to remove this strain

$$= \text{strain} \times E$$

or $\text{Stress} = E \times \text{strain}$

Consider now a compound bar constructed from two different materials rigidly joined together, for simplicity.

Let us consider that the materials in this case are steel and brass.

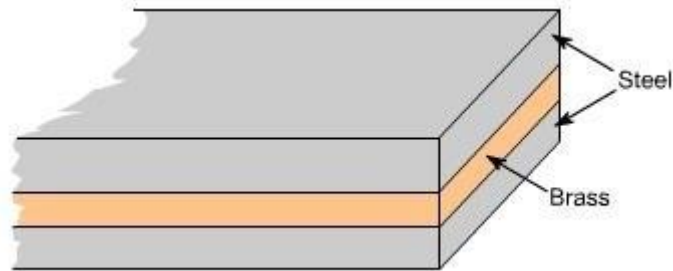

If we have both applied stresses and a temp. change, thermal strains may be added to those given by generalized hook's law equation –e.g.

$$\epsilon_x = \frac{1}{E} [\sigma_x - \nu(\sigma_y + \sigma_z)] + \alpha \Delta t$$

$$\epsilon_y = \frac{1}{E} [\sigma_y - \nu(\sigma_x + \sigma_z)] + \alpha \Delta t$$

$$\epsilon_z = \frac{1}{E} [\sigma_z - \nu(\sigma_x + \sigma_y)] + \alpha \Delta t$$

While the normal strains a body are affected by changes in temperatures, shear strains are not. Because if the temp. of any block or element changes, then its size changes not its shape therefore shear strains do not change.

In general, the coefficients of expansion of the two materials forming the compound bar will be different so that as the temp. rises each material will attempt to expand by different amounts. Figure below shows the positions to which the individual materials will expand if they are completely free to expand (i.e not joined rigidly together as a compound bar). The extension of any Length L is given by a L t

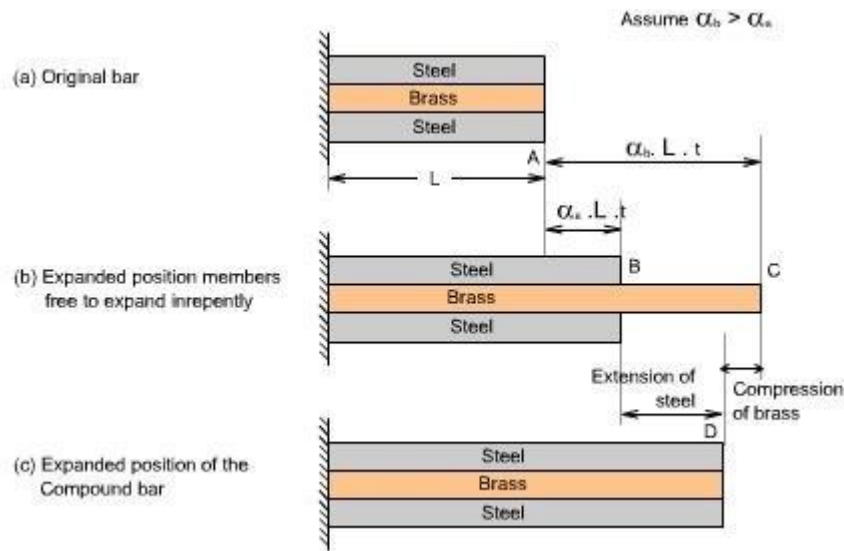

In general, changes in lengths due to thermal strains may be calculated from equation $d_t = \alpha L t$, provided that the members are able to expand or contract freely, a situation that exists in statically determinate structures. As a consequence no stresses are generated in a statically determinate structure when one or more members undergo a uniform temperature change. If in a structure (or a compound bar), the free expansion or contraction is not allowed then the member becomes statically indeterminate, which is just being discussed as an example of the compound bar and thermal stresses would be generated.

Thus the difference of free expansion lengths or so called free lengths

$$= \alpha_b L t - \alpha_s L t$$

$$= (\alpha_b - \alpha_s) L t$$

Since in this case the coefficient of expansion of the brass α_b is greater than that for the steel α_s , the initial lengths L of the two materials are assumed equal.

Conclusion 1.

Extension of steel + compression brass = difference in “free” length

Applying Newton's law of equal action and reaction the following second Conclusion also holds good.

Conclusion 2.

The tensile force applied to the short member by the long member is equal in magnitude to the compressive force applied to long member by the short member.

Thus in this case

Tensile force in steel = compressive force in brass

These conclusions may be written in the form of mathematical equations as given below:

for conclusion 1

$$\frac{\sigma_s \cdot L}{E_s} + \frac{\sigma_B \cdot L}{E_B} = (\alpha_B - \alpha_s) L \cdot t$$

for conclusion 2

$$\sigma_s \cdot A_s = \sigma_B \cdot A_B$$

Using these two equations, the magnitude of the stresses may be determined.

1. A steel rod of 20mm diameter passes centrally through a copper tube of 50mm external diameter and 40mm internal diameter. The tube is closed at each end by rigid plates of negligible thickness. The nuts are tightened lightly home on the projecting parts of the rod. If the temperature of the assembly is raised by 50°C, calculate the stress developed in copper and steel. Take E for steel and copper as 200 GN/m² and 100 GN/m² and α for steel and copper as 12 x 10⁻⁶ per °C and 18 x 10⁻⁶ per °C.

GIVEN DATA

Dia of steel rod = 20 mm

$$\text{Area of steel rod} = A_s = \frac{\pi}{4} \times 20^2 = 100\pi \text{ mm}^2$$

$$\text{Area of Copper tube} = A_c = \frac{\pi}{4} \times (50^2 - 40^2) = 225\pi \text{ mm}^2$$

Rise of temperature T = 50°C

$$E_s = 200 \text{ GN/m}^2 = 200 \times 10^3 \text{ N/mm}^2; \quad E_c = 100 \text{ GN/m}^2 = 100 \times 10^3 \text{ N/mm}^2$$

$$\alpha_s = 12 \times 10^{-6} \text{ per } ^\circ\text{C}; \quad \alpha_c = 18 \times 10^{-6} \text{ per } ^\circ\text{C}$$

TO FIND

Stresses developed in the steel

SOLUTION

$$\sigma_s \cdot A_s = \sigma_c \cdot A_c$$

$$\sigma_s = \frac{\sigma_c \cdot A_c}{A_s} = \frac{225\pi}{100\pi} \times \sigma_c$$

$$\sigma_s = 2.25\sigma_c$$

$$\alpha_s \cdot T \cdot L + \frac{\sigma_s}{E} \cdot L = \alpha_c \cdot T \cdot L + \frac{\sigma_c}{E} \cdot L$$

$$12 \times 10^{-6} \times 50 + \frac{2.25\sigma_c}{200 \times 10^3} = 18 \times 10^{-6} \times 50 + \frac{\sigma_c}{100 \times 10^3}$$

$$\sigma_c = 14.117 \text{ N/mm}^2$$

$$\sigma_s = 31.76 \text{ N} / \text{mm}^2$$

ELASTIC CONSTANTS

In considering the elastic behavior of an isotropic materials under, normal, shear and hydrostatic loading, we introduce a total of four elastic constants namely E, G, K, and μ .

It turns out that not all of these are independent to the others. In fact, given any two of them, the other two can be found out. Let us define these elastic constants

(i) E = Young's Modulus of Rigidity

$$= \text{Stress} / \text{strain}$$

(ii) G = Shear Modulus or Modulus of rigidity

$$= \text{Shear stress} / \text{Shear strain}$$

(iii) μ = Poisson's ratio

$$\mu = \text{lateral strain} / \text{longitudinal strain}$$

(iv) K = Bulk Modulus of elasticity

$$= \text{Volumetric stress} / \text{Volumetric strain}$$

Where

Volumetric strain = sum of linear strain in x, y and z direction.

Volumetric stress = stress which cause the change in volume.

Let us find the relations between them

Relation between E, G and K :

The relationship between E, G and K can be easily determined by eliminating μ from the already derived relations

$$E = 2 G (1 + \mu) \text{ and } E = 3 K (1 - 2\mu)$$

Thus, the following relationship may be obtained

$$E = \frac{9 G K}{(3K + G)}$$

1. Determine the change in length, breadth and thickness of a steel bar 4m long, 30mm wide and 20mm thick, when subjected to an axial pull of 120KN in the direction of its length. Take E= 200GPa and Poisson's ratio = 0.3.

Given: Length, $L = 4 \text{ m} = 4000 \text{ mm}$;
 Wide, $b = 30 \text{ mm}$
 Thickness, $t = 20 \text{ mm}$;
 Axial pull, $P = 120 \text{ kN} = 120 \times 10^3 \text{ N}$
 Young's Modulus, $E = 200 \text{ GPa}$
 $= 200 \times 10^9 \text{ Pa} = 200 \times 10^9 \text{ N/m}^2$
 $= 200 \times 10^3 \text{ N/mm}^2$;
 Poisson's ratio, $1/m = 0.3$

To find: 1. Change in length, δL ,
 2. Change in breadth, δb ,
 3. Change in thickness, δt .

☺ **Solution:** We know that,

$$\text{Young's Modulus, } E = \frac{\text{Tensile stress}}{\text{Tensile strain}}$$

$$= \frac{\sigma}{e_l}$$

$$\Rightarrow 200 \times 10^3 = \frac{\sigma}{e_l} = \frac{P}{A e_l} \quad \left[\because \text{Stress } \sigma = \frac{\text{Load}}{\text{Area}} = \frac{P}{A} \right]$$

$$\Rightarrow 200 \times 10^3 = \frac{120 \times 10^3}{\text{Breadth} \times \text{Thickness} \times e_l}$$

$$200 \times 10^3 = \frac{120 \times 10^3}{30 \times 20 \times e_l} \quad \Rightarrow \quad e_l = 1 \times 10^{-3}$$

$$\left. \begin{array}{l} \text{Tensile strain or} \\ \text{Longitudinal strain} \end{array} \right\} = \frac{\text{Change in length}}{\text{Original length}} = \frac{\delta L}{L}$$

$$e_l = \frac{\delta L}{4000} \Rightarrow 1 \times 10^{-3} = \frac{\delta L}{4000} \quad \Rightarrow \quad \delta L = 4 \text{ mm}$$

$$\text{Poisson's ratio} = \frac{\text{Lateral strain}}{\text{Longitudinal strain}} = \frac{e_t}{e_l}$$

$$\Rightarrow 0.3 = \frac{e_t}{1 \times 10^{-3}}$$

$$e_t = 3 \times 10^{-4}$$

$$\text{Lateral dimension, } e_t = \frac{\delta b}{b} \text{ or } \frac{\delta t}{t}$$

$$\Rightarrow e_t = \frac{\delta b}{b} \Rightarrow 3 \times 10^{-4} = \frac{\delta b}{30}$$

$$\text{Change in breadth, } \delta b = 9 \times 10^{-3} \text{ mm}$$

$$e_t = \frac{\delta t}{t} \Rightarrow 3 \times 10^{-4} = \frac{\delta t}{20}$$

$$\text{Change in thickness, } \delta t = 6 \times 10^{-3} \text{ mm}$$

Result: Change in length, $\delta L = 4 \text{ mm}$
 Change in breadth, $\delta b = 9 \times 10^{-3} \text{ mm}$
 Change in thickness, $\delta t = 6 \times 10^{-3} \text{ mm}$

Volumetric strains in terms of principal stresses:

As we know that

$$\epsilon_1 = \frac{\sigma_1}{E} - \mu \frac{\sigma_2}{E} - \mu \frac{\sigma_3}{E}$$

$$\epsilon_2 = \frac{\sigma_2}{E} - \mu \frac{\sigma_1}{E} - \mu \frac{\sigma_3}{E}$$

$$\epsilon_3 = \frac{\sigma_3}{E} - \mu \frac{\sigma_1}{E} - \mu \frac{\sigma_2}{E}$$

Further Volumetric strain $= \epsilon_1 + \epsilon_2 + \epsilon_3$

$$= \frac{(\sigma_1 + \sigma_2 + \sigma_3)}{E} - \frac{2\mu(\sigma_1 + \sigma_2 + \sigma_3)}{E}$$

$$= \frac{(\sigma_1 + \sigma_2 + \sigma_3)(1 - 2\mu)}{E}$$

hence the

$$\boxed{\text{Volumetric strain} = \frac{(\sigma_1 + \sigma_2 + \sigma_3)(1 - 2\mu)}{E}}$$

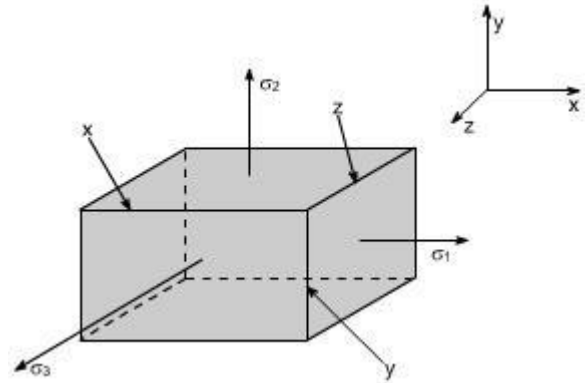

A bar of 30mm diameter is subjected to a pull of 60kN. The measured extension on gauge length of 200mm is 0.09mm and the change in diameter is 0.0039. Calculate the Poisson's ratio and value of three moduli.

- Given:**
- Diameter, $d = 30$ mm;
 - Pull, $P = 60$ kN $= 60 \times 10^3$ N
 - Length, $L = 200$ mm;
 - Change in length, $\delta L = 0.09$ mm
 - Change in diameter, $\delta d = 0.0039$ mm

- To find:**
1. Poisson's ratio, $1/m$,
 2. Young's Modulus, E ,
 3. Bulk Modulus, K ,
 4. Modulus of Rigidity, G .

☺ **Solution:** We know that,

$$\text{Poisson's ratio, } \frac{1}{m} = \frac{\text{Lateral strain}}{\text{Longitudinal strain}}$$

$$\frac{1}{m} = \frac{e_t}{e_l} \quad \dots (1)$$

$$\text{Lateral strain, } e_t = \frac{\delta b}{b} \text{ or } \frac{\delta d}{d} \text{ or } \frac{\delta t}{t}$$

$$e_t = \frac{\delta d}{d} = \frac{0.0039}{30}$$

$$\boxed{e_t = 1.3 \times 10^{-4}}$$

$$\text{Longitudinal strain, } e_l = \frac{\delta L}{L} = \frac{0.09}{200}$$

$$\boxed{e_l = 4.5 \times 10^{-4}}$$

We know that,

$$\text{Young's Modulus, } E = 2G \left(1 + \frac{1}{m} \right)$$

$$\Rightarrow 1.8 \times 10^5 = 2G (1 + 0.28)$$

$$\boxed{G = 7.0 \times 10^4 \text{ N/mm}^2}$$

$$\text{Young's Modulus, } E = 3K \left(1 - \frac{2}{m} \right)$$

$$\Rightarrow 1.8 \times 10^5 = 3K [1 - 2(0.28)]$$

$$\boxed{K = 1.36 \times 10^5 \text{ N/mm}^2}$$

Substituting e_t, e_l values in equation (1),

$$\Rightarrow \frac{1}{m} = \frac{1.3 \times 10^{-4}}{4.5 \times 10^{-4}} = 0.28$$

$$\boxed{\text{Poisson's ratio, } 1/m = 0.28}$$

$$\text{Young's Modulus, } E = \frac{\text{Tensile stress}}{\text{Tensile strain}} = \frac{\sigma}{e_l}$$

$$= \frac{P}{A e_l} \quad \left[\because \text{Stress } \sigma = \frac{\text{Load}}{\text{Area}} = \frac{P}{A} \right]$$

$$E = \frac{60 \times 10^3}{\frac{\pi}{4} d^2 \times 4.5 \times 10^{-4}}$$

$$= \frac{60 \times 10^3}{\frac{\pi}{4} (30)^2 \times 4.5 \times 10^{-4}}$$

$$\boxed{E = 1.8 \times 10^5 \text{ N/mm}^2}$$

A rod of length 1m and diameter 20mm is subjected to a tensile load of 20kN. The increase in length of the rod is 0.30 mm and the decrease in diameter is 0.0018 mm. Calculate the poisson's ratio and three moduli.

Given: Rod length, $L = 1 \text{ m} = 1000 \text{ mm}$

Diameter, $d = 20 \text{ mm}$

Load, $P = 20 \text{ kN} = 20 \times 10^3 \text{ N}$

Change in length, $\delta L = 0.30 \text{ mm}$

Change in diameter, $\delta d = 0.0018 \text{ mm}$

To find:

1. Poisson's ratio ($1/m$).
2. Young's modulus (E).
3. Bulk modulus (K).
4. Modulus of rigidity (G).

☺**Solution:** We know that,

$$\text{Poisson's ratio, } (1/m) = \frac{\text{Lateral strain}}{\text{Longitudinal strain}}$$

$$\Rightarrow \frac{1}{m} = \frac{e_t}{e_l} \quad \dots (1)$$

$$\text{Lateral strain, } e_t = \frac{\delta b}{b} \quad (\text{or}) \quad \frac{\delta d}{d} \quad (\text{or}) \quad \frac{\delta t}{t}$$

$$\Rightarrow e_t = \frac{\delta d}{d} = \frac{0.0018}{20}$$

$$\boxed{e_t = 90 \times 10^{-6}}$$

$$\text{Longitudinal strain, } e_l = \frac{\delta L}{L} = \frac{0.30}{1000}$$

$$\Rightarrow \boxed{e_l = 300 \times 10^{-6}}$$

Substituting e_t, e_l values in equation (1),

$$(1) \Rightarrow \frac{1}{m} = \frac{90 \times 10^{-6}}{300 \times 10^{-6}}$$

$$\Rightarrow \frac{1}{m} = 0.3$$

$$\boxed{\text{Poisson's ratio } (1/m) = 0.3}$$

We know that,

$$\text{Young's modulus, } E = \frac{\text{Tensile stress}}{\text{Tensile strain}}$$

$$= \frac{\sigma}{e_l} = \frac{P}{A e_l}$$

$$\left[\because \text{Stress, } \sigma = \frac{\text{Load}}{\text{Area}} = \frac{P}{A} \right]$$

$$\Rightarrow E = \frac{20 \times 10^3}{\frac{\pi}{4} d^2 \times 300 \times 10^{-6}}$$

$$= \frac{20 \times 10^3}{\frac{\pi}{4} (20)^2 \times 300 \times 10^{-6}}$$

$$\boxed{E = 2.12 \times 10^5 \text{ N/mm}^2}$$

We know that,

$$\text{Young's modulus, } E = 2G \left(1 + \frac{1}{m} \right)$$

$$\Rightarrow 2.12 \times 10^5 = 2 \times G (1 + 0.3)$$

$$2.12 \times 10^5 = 2.6 G$$

$$\Rightarrow G = 8.15 \times 10^4 \text{ N/mm}^2$$

$$\text{Modulus of rigidity, } G = 8.15 \times 10^4 \text{ N/mm}^2$$

We know that,

$$\text{Young's modulus, } E = 3K \left(1 - \frac{2}{m} \right)$$

$$\Rightarrow 2.12 \times 10^5 = 3 \times K [1 - 2 \times (0.3)]$$

$$\Rightarrow K = 1.76 \times 10^5 \text{ N/mm}^2$$

$$\text{Bulk modulus, } K = 1.76 \times 10^5 \text{ N/mm}^2$$

- Result:**
1. Poisson's ratio, $1/m = 0.3$
 2. Young's modulus, $E = 2.12 \times 10^5 \text{ N/mm}^2$
 3. Modulus of rigidity, $G = 8.15 \times 10^4 \text{ N/mm}^2$
 4. Bulk modulus, $K = 1.76 \times 10^5 \text{ N/mm}^2$

A steel plate 300mm long, 60mm wide and 30mm deep is acted upon by the forces shown in figure. Determine the change in volume. Take $E = 200 \text{ kN/mm}^2$ and Poisson's ratio = 0.3.

Given: Length $x = 300 \text{ mm}$; Width $y = 60 \text{ mm}$

Depth $z = 30 \text{ mm}$;

Load in the direction of $x = 50 \text{ kN}$
 $= 50 \times 10^3 \text{ N}$

Load in the direction of $y = -80 \text{ kN}$
 $= -80 \times 10^3 \text{ N}$

[\therefore Compressive load]

Load in the direction of $z = 75 \text{ kN} = 75 \times 10^3 \text{ N}$

Young's modulus $E = 200 \text{ kN/mm}^2 = 2 \times 10^5 \text{ N/mm}^2$

Poisson's ratio ($1/m$) = 0.3

To find: Change in volume (dV).

☺Solution:

$$\begin{aligned} \text{Stress in } x \text{ direction } \sigma_x &= \frac{\text{Load in } x \text{ direction}}{y \times z} \\ &= \frac{50 \times 10^3}{60 \times 30} \end{aligned}$$

$$\sigma_x = 27.77 \text{ N/mm}^2$$

$$\begin{aligned} \text{Stress in } y \text{ direction } \sigma_y &= \frac{\text{Load in } y \text{ direction}}{x \times z} \\ &= \frac{-80 \times 10^3}{300 \times 30} \end{aligned}$$

$$\sigma_y = -8.88 \text{ N/mm}^2$$

$$\begin{aligned} \text{Stress in } z \text{ direction } \sigma_z &= \frac{\text{Load in } z \text{ direction}}{x \times y} \\ &= \frac{75 \times 10^3}{300 \times 60} \end{aligned}$$

$$\sigma_z = 4.16 \text{ N/mm}^2$$

We know that,

$$\text{Change in volume } \frac{dV}{V} = \frac{1}{E} (\sigma_x + \sigma_y + \sigma_z) \left[1 - \frac{2}{m} \right]$$

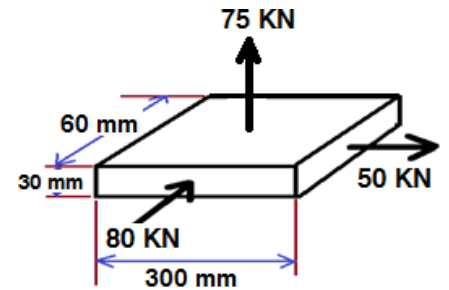

$$\Rightarrow \frac{dV}{V} = \frac{1}{2 \times 10^5} (27.77 - 8.88 + 4.16) \times [1 - 2 \times (0.3)]$$

$$\Rightarrow \frac{dV}{V} = 46.1 \times 10^{-6}$$

$$\Rightarrow dV = 46.1 \times 10^{-6} V$$

$$\Rightarrow dV = 46.1 \times 10^{-6} \times x \times y \times z \quad [\because V = x \times y \times z]$$

$$\Rightarrow dV = 46.1 \times 10^{-6} \times 300 \times 60 \times 30$$

$$\Rightarrow dV = 24.89 \text{ mm}^3$$

Result: Change in volume $dV = 24.89 \text{ mm}^3$

Stresses on inclined planes

Stresses on oblique plane: Till now we have dealt with either pure normal direct stress or pure shear stress. In many instances, however both direct and shear stresses acts and the resultant stress across any section will be neither normal nor tangential to the plane

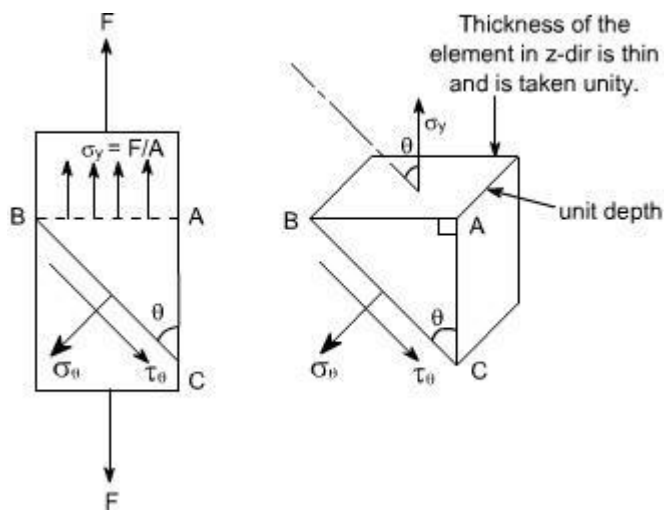

$$\sigma_{\theta} = \sigma_y \cdot \sin^2 2\theta$$

$$\tau_{\theta} = \frac{1}{2} \cdot \sigma_y \cdot \sin 2\theta$$

Material subjected to pure shear:

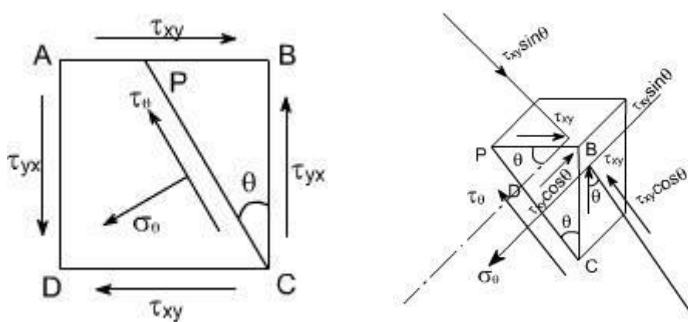

$$\sigma_{\theta} = \tau_{xy} \cdot \sin 2\theta$$

$$\tau_{\theta} = -\tau_{xy} \cos 2\theta$$

Material subjected to two mutually perpendicular direct stresses:

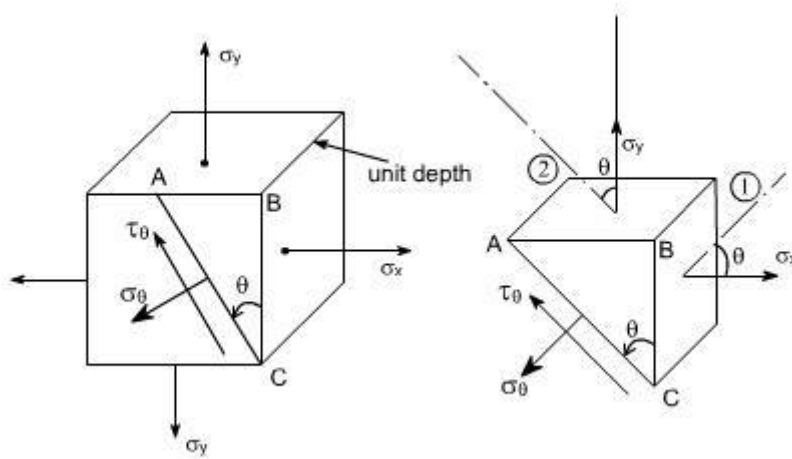

$$\sigma_{\theta} = \left(\frac{\sigma_x + \sigma_y}{2} \right) + \left(\frac{\sigma_x - \sigma_y}{2} \right) \cos 2\theta$$

$$\tau_{\theta} \cdot AC \cdot 1 = [\tau_x \cos \theta \sin \theta - \sigma_y \sin \theta \cos \theta] AC$$

$$\tau_{\theta} = (\sigma_x - \sigma_y) \sin \theta \cos \theta$$

$$= \frac{(\sigma_x - \sigma_y)}{2} \sin 2\theta$$

$$\text{or } \tau_{\theta} = \frac{(\sigma_x - \sigma_y)}{2} \sin 2\theta$$

$$\tau_{\max} = \frac{(\sigma_x - \sigma_y)}{2}$$

Material subjected to combined direct and shear stresses:

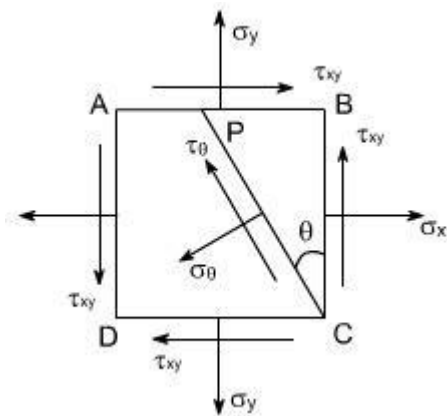

$$\sigma_{\theta} = \frac{(\sigma_x + \sigma_y)}{2} + \frac{(\sigma_x - \sigma_y)}{2} \cos 2\theta$$

$$\tau_{\theta} = \frac{(\sigma_x - \sigma_y)}{2} \sin 2\theta$$

$$\sigma_{\theta} = \frac{(\sigma_x + \sigma_y)}{2} + \frac{(\sigma_x - \sigma_y)}{2} \cos 2\theta + \tau_{xy} \sin 2\theta$$

$$\tau_{\theta} = \frac{(\sigma_x - \sigma_y)}{2} \sin 2\theta - \tau_{xy} \cos 2\theta$$

$$\text{For } \sigma_{\theta} \text{ to be a maximum or minimum } \frac{d\sigma_{\theta}}{d\theta} = 0$$

Now

$$\sigma_{\theta} = \frac{(\sigma_x + \sigma_y)}{2} + \frac{(\sigma_x - \sigma_y)}{2} \cos 2\theta + \tau_{xy} \sin 2\theta$$

$$\frac{d\sigma_{\theta}}{d\theta} = -\frac{1}{2}(\sigma_x - \sigma_y) \sin 2\theta \cdot 2 + \tau_{xy} \cos 2\theta \cdot 2$$

$$= 0$$

$$\text{i.e. } -(\sigma_x - \sigma_y) \sin 2\theta + \tau_{xy} \cos 2\theta = 0$$

$$\tau_{xy} \cos 2\theta = (\sigma_x - \sigma_y) \sin 2\theta$$

$$\text{Thus, } \tan 2\theta = \frac{2\tau_{xy}}{(\sigma_x - \sigma_y)}$$

GRAPHICAL SOLUTION – MOHR'S STRESS CIRCLE

The transformation equations for plane stress can be represented in a graphical form known as Mohr's circle. This graphical representation is very useful in depicting the relationships between normal and shear stresses acting on any inclined plane at a point in a stressed body.

To draw a Mohr's stress circle consider a complex stress system as shown in the figure

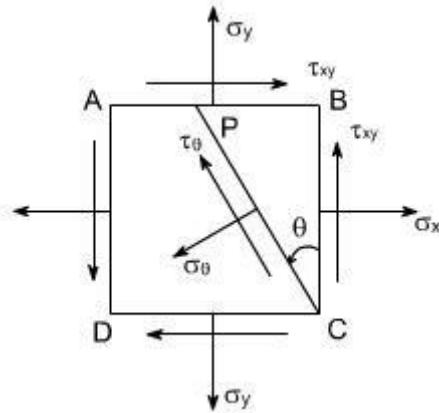

The above system represents a complete stress system for any condition of applied load in two dimensions

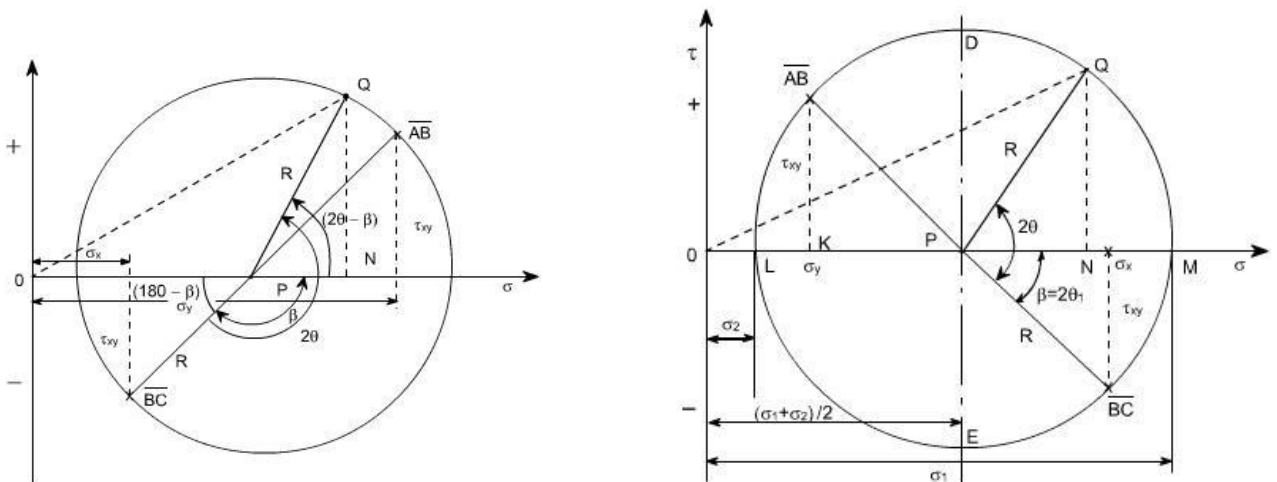

1. The stresses at a point in a strained material is $P_x = 200 \text{ N/mm}^2$ and $P_y = -150 \text{ N/mm}^2$ and $q = 80 \text{ N/mm}^2$. Find the principal plane and principal stresses. Using graphical method and verify with analytical method. (Solve both methods)

☺ **Solution: Graphical method:**

1. Draw a horizontal line and set off OA and OB equal to σ_1 and σ_2 on opposite sides to the scale, since both the stresses are opposite to each other.

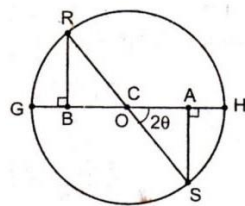

2. Bisect BA at C.
3. Draw perpendicular line AS from A which is equal to shear stress. 80 N/mm^2 and to the same scale draw BR from B.
4. With C as centre and CS as radius draw a circle. This is known as Mohr's circle.

4. By measurement, we find

$$\text{Major principal stress, } \sigma_{n1} = \text{OH} = 215 \text{ N/mm}^2$$

Analytical method:

Major principal stress,

$$\begin{aligned} \sigma_{n1} &= \frac{\sigma_1 + \sigma_2}{2} + \frac{1}{2} \sqrt{(\sigma_1 - \sigma_2)^2 + 4q^2} \\ &= \frac{200 - 150}{2} + \frac{1}{2} \sqrt{[200 - (-150)]^2 + 4(80)^2} \\ &= 217.4 \text{ N/mm}^2 \end{aligned}$$

Minor principal stress,

$$\begin{aligned} \sigma_{n2} &= \frac{\sigma_1 + \sigma_2}{2} - \frac{1}{2} \sqrt{(\sigma_1 - \sigma_2)^2 + 4q^2} \\ &= \frac{200 - 150}{2} - \frac{1}{2} \sqrt{[200 - (-150)]^2 + 4(80)^2} \\ &= -167.4 \text{ N/mm}^2 \end{aligned}$$

Location of principal plane,

$$\begin{aligned} \tan 2\theta &= \frac{2q}{\sigma_1 - \sigma_2} \\ &= \frac{2 \times 80}{200 + 150} \end{aligned}$$

$$\tan 2\theta = 0.457$$

$$\Rightarrow 2\theta = 24.56 \Rightarrow \theta = 12.28^\circ \text{ or } 102.28^\circ$$

$$\text{Minor principal stress, } \sigma_{n2} = \text{OG} = -165 \text{ N/mm}^2$$

$$\text{Location of principal plane, } 2\theta = \angle \text{SCA} = 24.5^\circ$$

$$\theta = 12.25^\circ$$

Results: From the above two methods we found that both the answers were very close to each other.

$$\text{Major principal stress, } \sigma_{n1} = 217.4 \text{ N/mm}^2$$

$$\text{Minor principal stress, } \sigma_{n2} = -167.4 \text{ N/mm}^2$$

$$\text{Location of principal plane, } \theta = 12.28^\circ \text{ or } 102.28^\circ$$

At a point in a strained material, the principal stresses are 100 N/mm^2 tensile and 60 N/mm^2 compressive. Calculate the normal stress, shear stress and resultant stress on a plane inclined at 50° to the axis of major principal stress.

Given:

$$\sigma_1 = 100 \text{ N/mm}^2$$

$$\sigma_2 = -60 \text{ N/mm}^2$$

(i.e., compressive)

$$\theta = 50^\circ$$

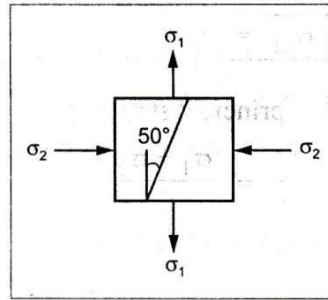

To find: Normal stress, shear stress and resultant stress on 50° inclined plane.

☺ **Solution:**

$$\begin{aligned} \text{Normal stress, } \sigma_n &= \frac{\sigma_1 + \sigma_2}{2} + \frac{\sigma_1 - \sigma_2}{2} \cos 2\theta \\ & \quad \text{[From equation (1.50)]} \\ &= \frac{100 - 60}{2} + \frac{100 - (-60)}{2} \cos (2 \times 50) \\ &= 20 + 80 \cos 100^\circ \end{aligned}$$

$$\boxed{\sigma_n = 6.108 \text{ N/mm}^2}$$

Tangential or shear stress,

$$\begin{aligned} \sigma_t &= \frac{\sigma_1 - \sigma_2}{2} \times \sin 2\theta \\ &= \frac{100 - (-60)}{2} \times \sin (2 \times 50) \\ &= 80 \times \sin 100 \\ &= 78.78 \text{ N/mm}^2 \end{aligned}$$

$$\boxed{\sigma_t = 78.78 \text{ N/mm}^2}$$

$$\begin{aligned} \text{Resultant stress, } \sigma_{res} &= \sqrt{\sigma_n^2 + \sigma_t^2} \quad \text{[From equation (1.52)]} \\ &= \sqrt{6.108^2 + 78.78^2} \end{aligned}$$

$$\boxed{\sigma_{res} = 79.02 \text{ N/mm}^2}$$

Results:

$$\text{Normal stress, } \sigma_n = 6.108 \text{ N/mm}^2$$

$$\text{Shear stress, } \sigma_t = 78.78 \text{ N/mm}^2$$

$$\text{Resultant stress, } \sigma_{res} = 79.02 \text{ N/mm}^2$$

A point in a strained material is subjected to mutually perpendicular stresses of 600 N/mm^2 (tensile) and 400 N/mm^2 (compressive). It's also subjected to a shear stress of 100 N/mm^2 . Draw the Mohr's circle & find the principle stress & max. shear stress from diagram.

To find: From Mohr's circle,

1. Principal stresses
2. Maximum shear stress

☺ **Solution:**

1. Draw a horizontal line and set off OA and OB equal to 600 N/mm^2 and 400 N/mm^2 on the opposite side to some scale, since both stresses are opposite side to each other.
2. Bisect BA. at C
3. Draw perpendicular line AS or RB which is equal to shear stress 100 N/mm^2 to the same scale.
4. With C as centre and CS as radius, draw a circle. This is known as Mohr's circle.
5. Draw a line CG' perpendicular to AB, which will gives the maximum shear stress value.

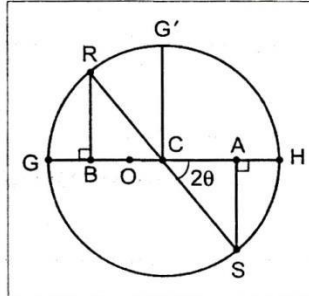

By measurement,

$$\text{Major principal stress, } \sigma_{n1} = \text{OH} = 610 \text{ N/mm}^2$$

$$\text{Minor principal stress, } \sigma_{n2} = \text{OG} = -410 \text{ N/mm}^2$$

$$\text{Maximum shear stress, } (\sigma_t)_{\max} = \text{CG}' = 510 \text{ N/mm}^2$$

A 5mm thick aluminium plate has a width of 300mm and a length of 600mm subjected to pull of 15000N and 9000N respectively in axial and transverse direction. Determine the normal, tangential and resultant stresses on a plane 40 degree to the greatest stress.

Given:

$$\text{Width, } b = 300 \text{ mm}$$

$$\text{Length, } l = 600 \text{ mm}$$

$$\text{Thickness, } t = 5 \text{ mm}$$

$$\text{Axial load, } P_1 = 15000 \text{ N}$$

$$\text{Transverse load, } P_2 = 9000 \text{ N}$$

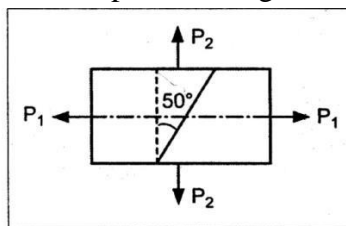

To find: Normal (σ_n), tangential (σ_t) and resultant stresses on a plane 40° to the greatest stress.

☺ **Solution: Analytical method:**

$$\begin{aligned}\text{Axial stress, } \sigma_1 &= \frac{\text{Axial load}}{\text{Area}} \\ &= \frac{15000}{5 \times 300} = 10 \text{ N/mm}^2\end{aligned}$$

$$\begin{aligned}\text{Transverse stress, } \sigma_2 &= \frac{\text{Transverse load}}{\text{Area}} = \frac{9000}{600 \times 5} \\ &= 3 \text{ N/mm}^2\end{aligned}$$

$$\text{Normal stress, } \sigma_n = \frac{\sigma_1 + \sigma_2}{2} + \frac{\sigma_1 - \sigma_2}{2} \cos 2\theta$$

[From equation (1.50)]

In this problem maximum stress is σ which is horizontal.

Therefore, $\theta = 90^\circ - 40^\circ = 50^\circ$ to the vertical

$$\begin{aligned}\Rightarrow \sigma_n &= \frac{10 + 3}{2} + \frac{10 - 3}{2} \cos (2 \times 50^\circ) \\ &= 5.89 \text{ N/mm}^2\end{aligned}$$

$$\text{Tangential stress, } \sigma_t = \frac{\sigma_1 - \sigma_2}{2} \times \sin (2\theta)$$

$$= \frac{10 - 3}{2} \times \sin 100^\circ$$

$$\sigma_t = 3.447 \text{ N/mm}^2$$

$$\begin{aligned}\text{Resultant stress, } \sigma_{res} &= \sqrt{\sigma_n^2 + \sigma_t^2} \\ &= \sqrt{5.89^2 + 3.447^2} \\ \sigma_{res} &= 6.82 \text{ N/mm}^2\end{aligned}$$

Graphical method:

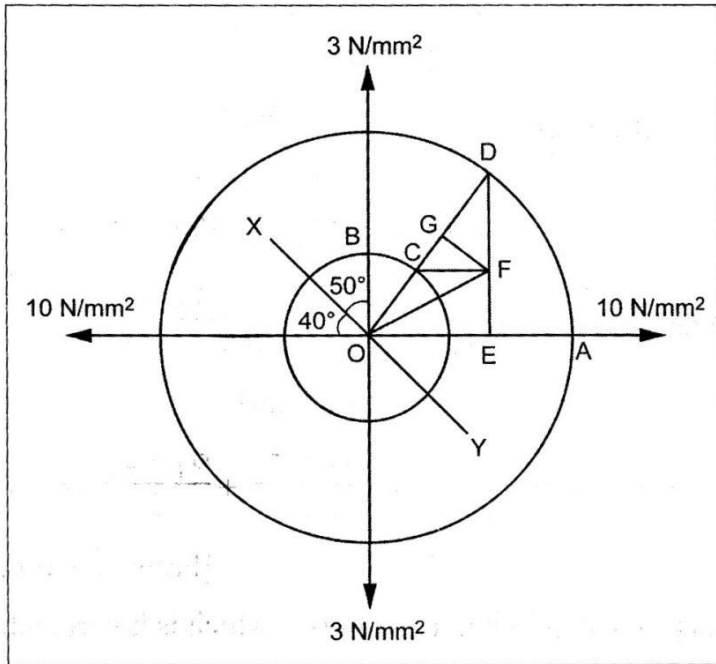

1. Draw two perpendicular lines meeting at O representing the direction of stresses 10 N/mm^2 and 3 N/mm^2 .
2. With O as centre, draw two concentric circles of radii OA and OB equal to 10 N/mm^2 and 3 N/mm^2 to some scale.
3. Draw the line XY through O which makes an angle 50° with the plane of 3 N/mm^2 stress.
4. From O, draw the line OCD which is perpendicular to the line XY and meeting the circle at C and D.
5. Draw DE perpendicular to OA and draw CF perpendicular to DE.
6. Join OF which is equal to resultant stress σ_{res} across the plane XY.
7. From F, draw a line FG perpendicular to OD.

By measurements,

Normal stress, $\sigma_n = OG = 6 \text{ N/mm}^2$

Tangential stress, $\sigma_t = GF = 3.4 \text{ N/mm}^2$

Resultant stress, $\sigma_{res} = OF = 6.9 \text{ N/mm}^2$

Result:

Normal stress, $\sigma_n = 6 \text{ N/mm}^2$

Tangential stress, $\sigma_t = 3.4 \text{ N/mm}^2$

Resultant stress, $\sigma_{res} = 6.9 \text{ N/mm}^2$

At a point in a strained body subjected to two mutually perpendicular normal tensile stresses of magnitude 30 MPa and 12 MPa accompanied by a shear stress of 16 MPa . Locate the principal planes and evaluate the principal stresses. Also calculate maximum shear stress. Check your answer in graphical method using Mohr's circle.

Given:

$$\sigma_1 = 30 \text{ MPa} = 30 \text{ N/mm}^2$$

$$\sigma_2 = 12 \text{ MPa} = 12 \text{ N/mm}^2$$

$$q = 16 \text{ MPa}$$

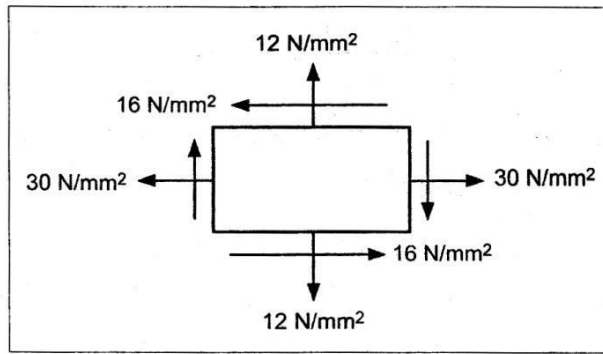

- To find:**
1. Location of principal planes, θ
 2. Principal stresses, σ_{n1}, σ_{n2}
 3. Maximum shear stress, $\sigma_t \text{ max}$

☺ **Solution: Analytical method:**

For this case, by using relation,

$$\tan 2\theta = \frac{2q}{\sigma_1 - \sigma_2}$$

$$\tan 2\theta = \frac{2 \times 16}{30 - 12} = 1.777$$

$$2\theta = 60^\circ 38'$$

$$\theta = 30^\circ 19' \text{ or } 120^\circ 19'$$

Major principal stress,

$$\begin{aligned} \sigma_{n1} &= \frac{\sigma_1 + \sigma_2}{2} + \frac{1}{2} \sqrt{(\sigma_1 - \sigma_2)^2 + 4q^2} \\ &= \frac{30 + 12}{2} + \frac{1}{2} \sqrt{(30 - 12)^2 + 4 \times 16^2} \\ \sigma_{n1} &= 39.36 \text{ N/mm}^2 \end{aligned}$$

Minor principal stress,

$$\begin{aligned} \sigma_{n2} &= \frac{\sigma_1 + \sigma_2}{2} - \frac{1}{2} \sqrt{(\sigma_1 - \sigma_2)^2 + 4q^2} \\ &= \frac{30 + 12}{2} - \frac{1}{2} \sqrt{(30 - 12)^2 + 4 \times 16^2} \\ \sigma_{n2} &= 2.642 \text{ N/mm}^2 \end{aligned}$$

Maximum shear stress,

$$\begin{aligned}
 (\sigma_t)_{\max} &= \frac{1}{2} \sqrt{(\sigma_1 - \sigma_2)^2 + 4q^2} \\
 &= \frac{1}{2} \sqrt{(30 - 12)^2 + 4 \times 16^2} \\
 (\sigma_t)_{\max} &= 18.36 \text{ N/mm}^2
 \end{aligned}$$

Mohr's Circle Method:

1. Draw a horizontal line and set off OA and OB equal to the stresses 30 N/mm² and 12 N/mm² on the same side to some suitable scale, since both are tensile stresses.
2. Bisect BA at C.
3. From A and B draw perpendicular lines AS and RB which is equal to shear stress 16 N/mm² to the same scale as shown in Fig.
4. With C as center and CS or CR as radius draw a circle which meets the horizontal line at G and H.

By measurement,

Major principal stress,

$$\sigma_{n1} = OH = 39.5 \text{ N/mm}^2$$

Minor principal stress,

$$\sigma_{n2} = OG = 2.625 \text{ N/mm}^2$$

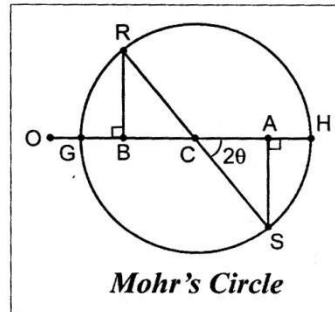

Mohr's Circle

Location of principal stresses

$$\text{Angle } \angle SCA = 2\theta = 60^\circ$$

$$\theta = 30^\circ \text{ or } 120^\circ$$

Maximum shear stress,

$$(\sigma_t)_{\max} = CS \text{ or } CR = 18.5 \text{ N/mm}^2$$

Results:

1. Location of principal planes, $\theta = 30^\circ 19' \text{ or } 120^\circ 19'$
2. Major principal stress, $\sigma_{n1} = 39.36 \text{ N/mm}^2$
3. Minor principal stress, $\sigma_{n2} = 2.642 \text{ N/mm}^2$
4. Maximum shear stress, $(\sigma_t)_{\max} = 18.36 \text{ N/mm}^2$

UNIT-II

TRANSVERSE LOADING ON BEAMS AND STRESSES IN BEAM

A **beam** is a [[structural element]] that primarily resists loads applied laterally to the beam's axis. Its mode of deflection is primarily by bending. The loads applied to the beam result in reaction forces at the beam's support points. The total effect of all the forces acting on the beam is to produce shear forces and bending moments within the beam, that in turn induce internal stresses, strains and deflections of the beam. Beams are characterized by their manner of support, profile (shape of cross-section), equilibrium conditions, length, and their material.

Types of beams

1. Simply supported – a beam supported on the ends which are free to rotate and have no moment resistance.
2. Fixed – a beam supported on both ends and restrained from rotation.
3. Over hanging – a simple beam extending beyond its support on one end.
4. Double overhanging – a simple beam with both ends extending beyond its supports on both ends.
5. Continuous – a beam extending over more than two supports.
6. Cantilever – a projecting beam fixed only at one end.
7. Trussed – a beam strengthened by adding a cable or rod to form a truss.

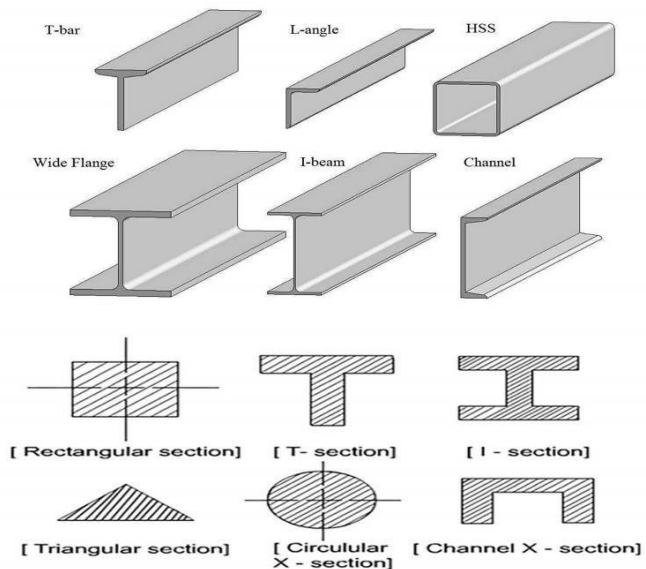
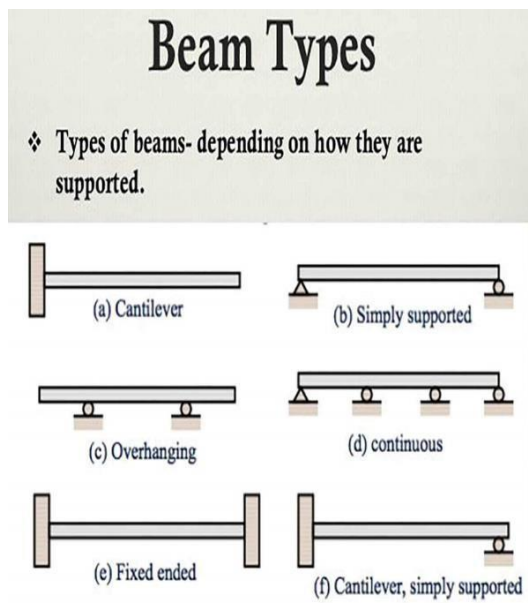

Types of Transverse loading on Beams;

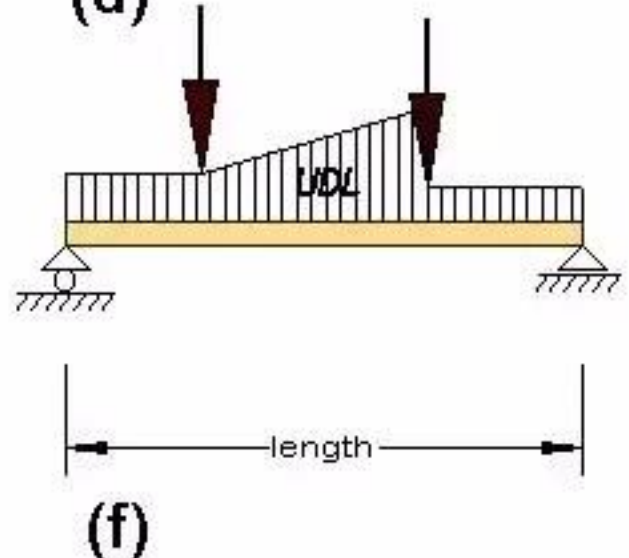
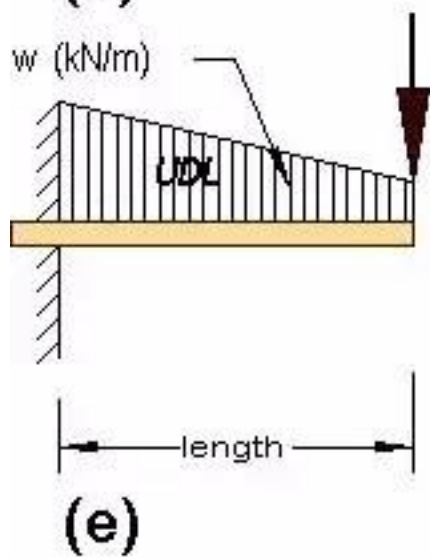
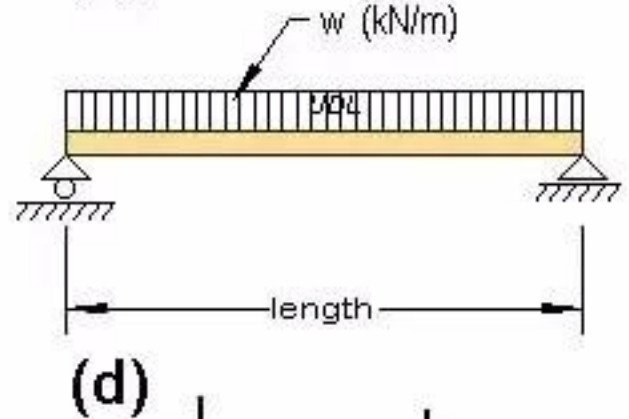
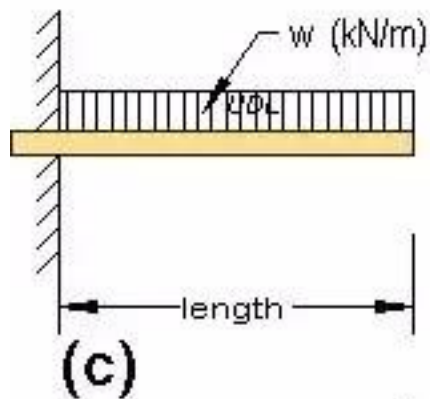
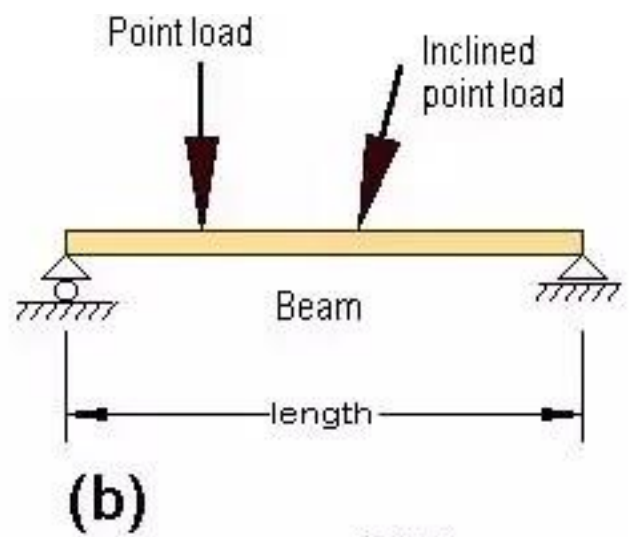
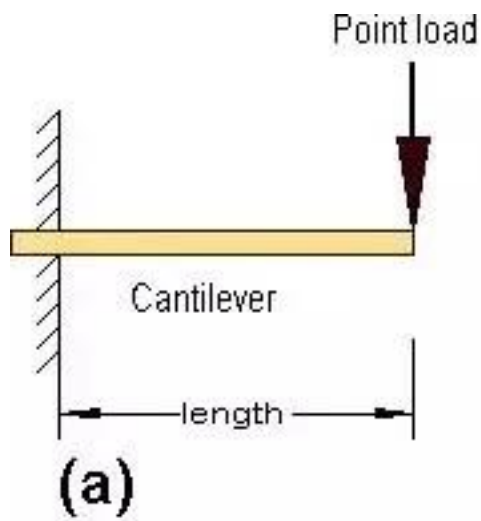

Concept of Shear Force and Bending moment in beams:

When the beam is loaded in some arbitrarily manner, the internal forces and moments are developed and the terms shear force and bending moments come into pictures which are helpful to analyze the beams further. Let us define these terms

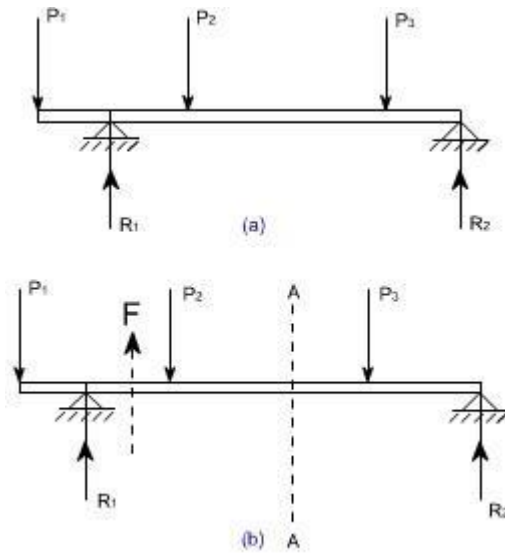

Fig 1

Now let us consider the beam as shown in fig 1(a) which is supporting the loads P_1 , P_2 , P_3 and is simply supported at two points creating the reactions R_1 and R_2 respectively. Now let us assume that the beam is to be divided into or imagined to be cut into two portions at a section AA. Now let us assume that the resultant of loads and reactions to the left of AA is 'F' vertically upwards, and since the entire beam is to remain in equilibrium, thus the resultant of forces to the right of AA must also be F, acting downwards. This force 'F' is a shear force. The shearing force at any x-section of a beam represents the tendency for the portion of the beam to one side of the section to slide or shear laterally relative to the other portion.

Therefore, now we are in a position to define the shear force 'F' to as follows:

At any x-section of a beam, the shear force 'F' is the algebraic sum of all the lateral components of the forces acting on either side of the x-section.

Sign Convention for Shear Force:

The usual sign conventions to be followed for the shear forces have been illustrated in figures 2 and 3.

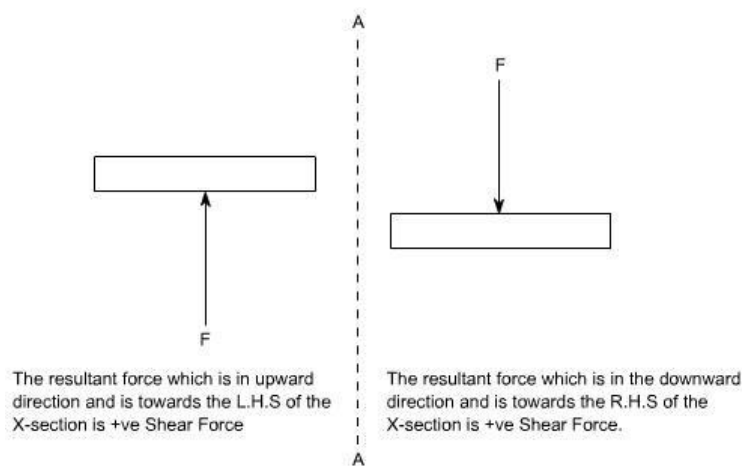

Fig 2: Positive Shear Force

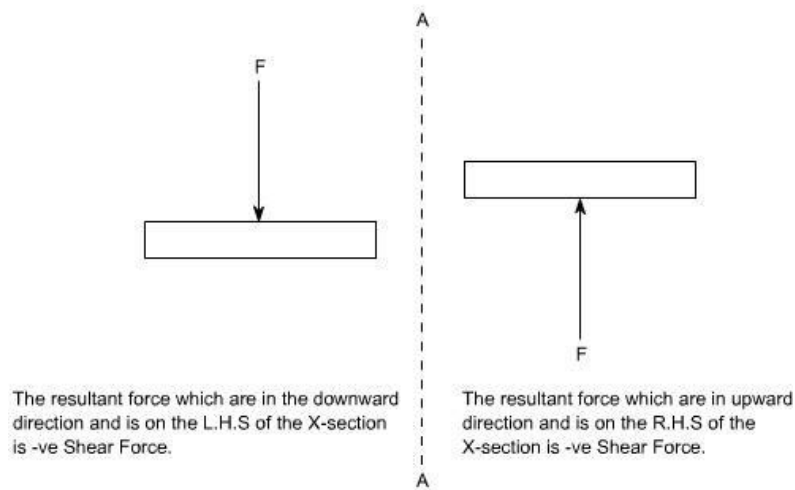

Fig 3: Negative Shear Force

Bending Moment:

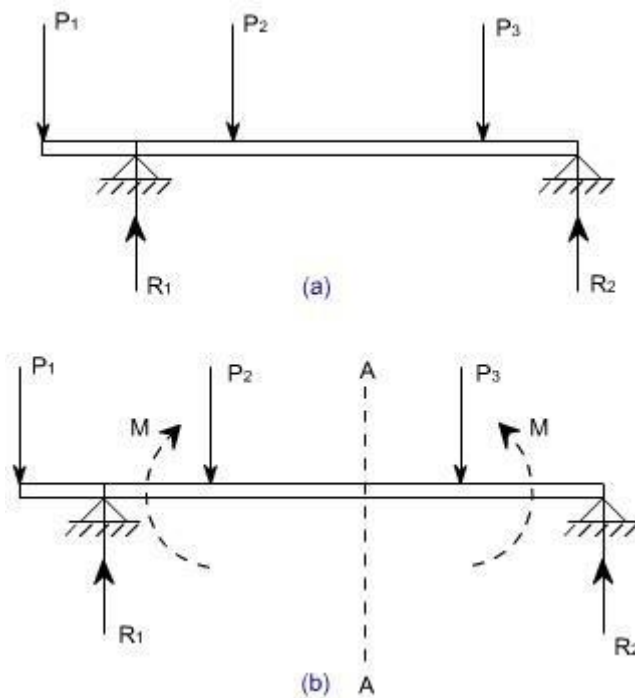

Fig 4

Let us again consider the beam which is simply supported at the two prints, carrying loads P_1 , P_2 and P_3 and having the reactions R_1 and R_2 at the supports Fig 4. Now, let us imagine that the beam is cut into two potions at the x-section AA. In a similar manner, as done for the case of shear force, if we say that the resultant moment about the section AA of all the loads and reactions to the left of the x-section at AA is M in C.W direction, then moment of forces to the right of x-section AA must be ' M ' in C.C.W. Then ' M ' is called as the Bending moment and is abbreviated as B.M. Now one can define the bending moment to be simply as the algebraic sum of the moments about an x-section of all the forces acting on either side of the section

Sign Conventions for the Bending Moment:

For the bending moment, following sign conventions may be adopted as indicated in Fig 5 and Fig 6.

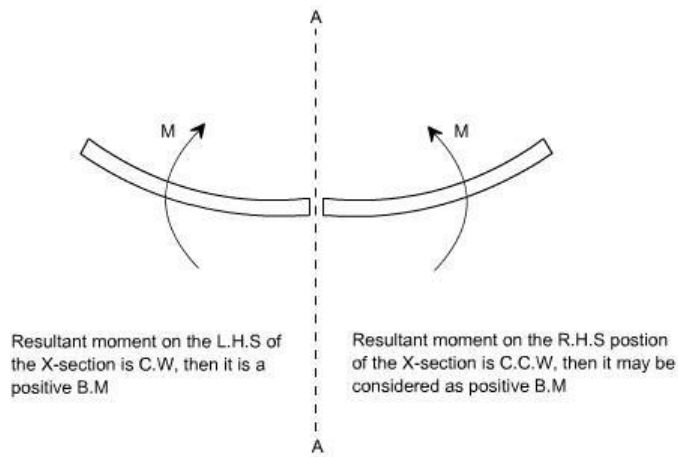

Fig5: Positive Bending Moment

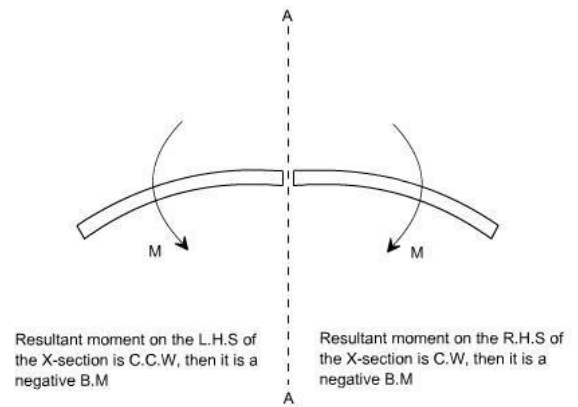

Fig 6: Negative Bending Moment

Some times, the terms 'Sagging' and Hogging are generally used for the positive and negative bending moments respectively.

Procedure for drawing shear force and bending moment diagram:

Preamble:

The advantage of plotting a variation of shear force F and bending moment M in a beam as a function of 'x' measured from one end of the beam is that it becomes easier to determine the maximum absolute value of shear force and bending moment.

Further, the determination of value of M as a function of 'x' becomes of paramount importance so as to determine the value of deflection of beam subjected to a given loading.

Construction of shear force and bending moment diagrams:

A shear force diagram can be constructed from the loading diagram of the beam. In order to draw this, first the reactions must be determined always. Then the vertical components of forces and reactions are successively summed from the left end of the beam to preserve the mathematical sign conventions adopted. The shear at a section is simply equal to the sum of all the vertical forces to the left of the section.

When the successive summation process is used, the shear force diagram should end up with the previously calculated shear (reaction at right end of the beam. No shear force acts through the beam just beyond the last vertical force or reaction. If the shear force diagram closes in this fashion, then it gives an important check on mathematical calculations.

The bending moment diagram is obtained by proceeding continuously along the length of beam from the left hand end and summing up the areas of shear force diagrams giving due regard to sign. The process of obtaining the moment diagram from the shear force diagram by summation is exactly the same as that for drawing shear force diagram from load diagram.

It may also be observed that a constant shear force produces a uniform change in the bending moment, resulting in straight line in the moment diagram. If no shear force exists along a certain portion of a beam, then it indicates that there is no change in moment takes place. It may also further observe that $dm/dx = F$ therefore, from the fundamental theorem of calculus the maximum or minimum moment occurs where the shear is zero. In order to check the validity of the bending moment diagram, the terminal conditions for the moment must be satisfied. If the end is free or pinned, the computed sum must be equal to zero. If the end is built in, the

moment computed by the summation must be equal to the one calculated initially for the reaction. These conditions must always be satisfied.

Simply supported beam subjected to a central load (i.e. load acting at the mid-way)

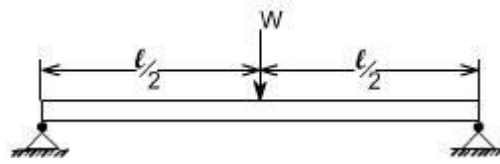

By symmetry the reactions at the two supports would be $W/2$ and $W/2$. now consider any section X-X from the left end then, the beam is under the action of following forces.

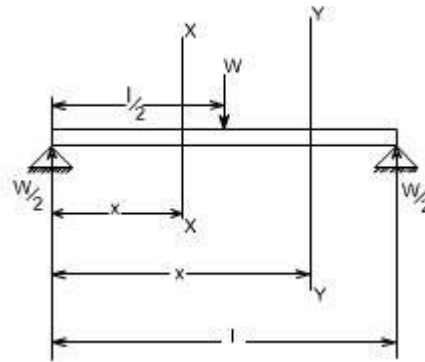

.So the shear force at any X-section would be = $W/2$ [Which is constant upto $x < l/2$]

If we consider another section Y-Y which is beyond $l/2$ then

$$S.F_{Y-Y} = \frac{W}{2} - W = \frac{-W}{2} \text{ for all values greater } = l/2$$

Hence S.F diagram can be plotted as,

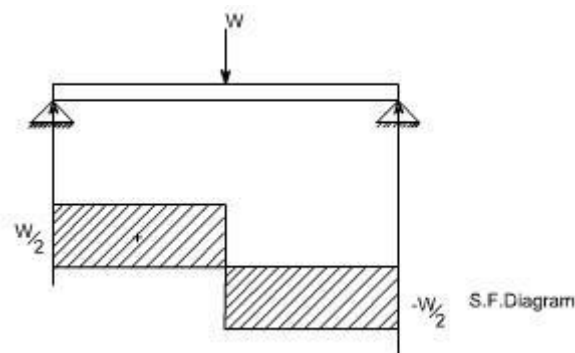

.For B.M diagram:

If we just take the moments to the left of the cross-section,

$$B.M_{x-x} = \frac{W}{2} x \text{ for } x \text{ lies between } 0 \text{ and } l/2$$

$$B.M_{\text{at } x = \frac{l}{2}} = \frac{W}{2} \cdot \frac{l}{2} \text{ i.e. } B.M. \text{ at } x = 0$$

$$= \frac{Wl}{4}$$

$$B.M_{y-y} = \frac{W}{2} x - W \left(x - \frac{l}{2} \right)$$

Again

$$= \frac{W}{2} x - Wx + \frac{Wl}{2}$$

$$= -\frac{W}{2} x + \frac{Wl}{2}$$

$$B.M_{\text{at } x = l} = -\frac{Wl}{2} + \frac{Wl}{2}$$

$$= 0$$

Which when plotted will give a straight relation i.e.

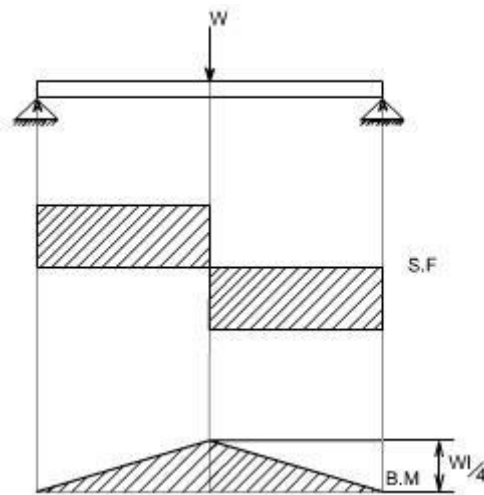

It may be observed that at the point of application of load there is an abrupt change in the shear force, at this point the B.M is maximum.

A cantilever beam subjected to U.d.L, draw S.F and B.M diagram.

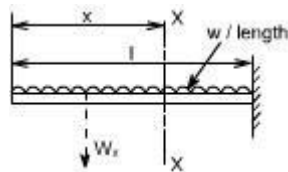

Here the cantilever beam is subjected to a uniformly distributed load whose intensity is given w / length .

Consider any cross-section XX which is at a distance of x from the free end. If we just take the resultant of all the forces on the left of the X-section, then

$$S.F_{xx} = -Wx \text{ for all values of 'x' -----(1)}$$

$$S.F_{xx} = 0$$

$$S.F_{xx} \text{ at } x=l = -Wl$$

So if we just plot the equation No. (1), then it will give a straight line relation. Bending Moment at X-X is obtained by treating the load to the left of X-X as a concentrated load of the same value acting through the centre of gravity.

Therefore, the bending moment at any cross-section X-X is

$$\begin{aligned} B.M_{x-x} &= -Wx \frac{x}{2} \\ &= -W \frac{x^2}{2} \end{aligned}$$

The above equation is a quadratic in x, when B.M is plotted against x this will produce a parabolic variation.

The extreme values of this would be at $x = 0$ and $x = l$

$$\begin{aligned} B.M_{\text{at } x=l} &= -\frac{Wl^2}{2} \\ &= \frac{Wl}{2} - Wx \end{aligned}$$

Hence S.F and B.M diagram can be plotted as follows:

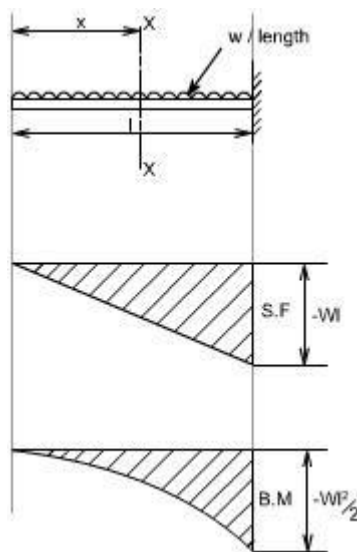

Simply supported beam subjected to a uniformly distributed load [U.D.L].

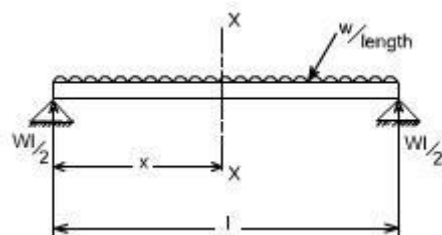

The total load carried by the span would be

= intensity of loading x length

$$= w \times l$$

By symmetry the reactions at the end supports are each $wl/2$

If x is the distance of the section considered from the left hand end of the beam.

S.F at any X-section X-X is

$$\begin{aligned} &= \frac{wl}{2} - wx \\ &= w \left(\frac{l}{2} - x \right) \end{aligned}$$

Giving a straight relation, having a slope equal to the rate of loading or intensity of the loading.

$$\text{S.F. at } x=0 = \frac{wl}{2} - wx$$

so at

$$\text{S.F. at } x = \frac{l}{2} = 0 \text{ hence the S.F is zero at the centre}$$

$$\text{S.F. at } x=l = -\frac{wl}{2}$$

The bending moment at the section x is found by treating the distributed load as acting at its centre of gravity, which at a distance of $x/2$ from the section

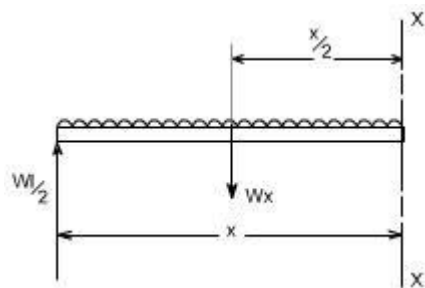

$$\text{B.M.}_{x,x} = \frac{wl}{2} x - wx \cdot \frac{x}{2}$$

so the

$$= w \cdot \frac{x}{2} (l - x) \dots\dots\dots(2)$$

$$\text{B.M.}_{\text{at } x=0} = 0$$

$$\text{B.M.}_{\text{at } x=l} = 0$$

$$\text{B.M.}_{\text{at } x=l} = -\frac{wl^2}{8}$$

So the equation (2) when plotted against x gives rise to a parabolic curve and the shear force and bending moment can be drawn in the following way will appear as follows:

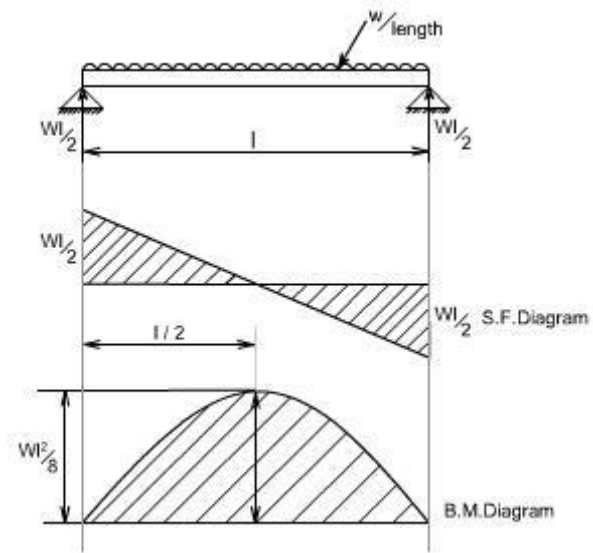

5. Couple.

When the beam is subjected to couple, the shear force and Bending moment diagrams may be drawn exactly in the same fashion as discussed earlier.

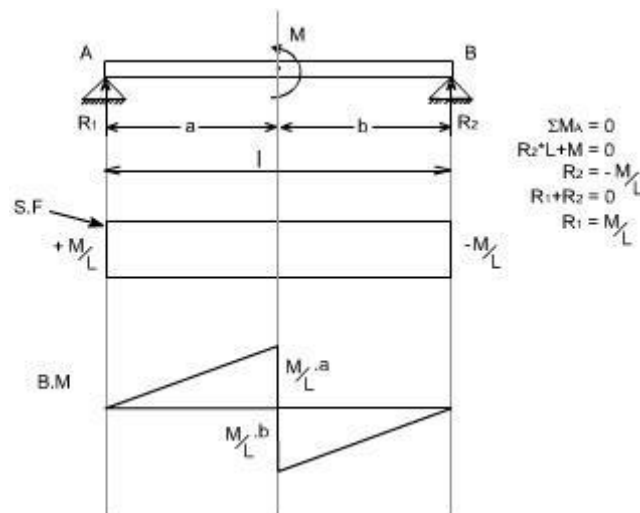

Simple Bending Theory OR Theory of Flexure for Initially Straight Beams

(The normal stress due to bending are called flexure stresses)

Preamble:

When a beam having an arbitrary cross section is subjected to a transverse loads the beam will bend. In addition to bending the other effects such as twisting and buckling may occur, and to investigate a problem that includes all the combined effects of bending, twisting and buckling could become a complicated one. Thus we are interested to investigate the bending effects alone, in order to do so, we have to put certain constraints on the geometry of the beam and the manner of loading.

Assumptions:

The constraints put on the geometry would form the **assumptions**:

1. Beam is initially **straight** , and has a **constant cross-section**.

2. Beam is made of **homogeneous material** and the beam has a **longitudinal plane of symmetry**.
3. Resultant of the applied loads lies in the plane of symmetry.
4. The geometry of the overall member is such that bending not buckling is the primary cause of failure.
5. Elastic limit is nowhere exceeded and 'E' is same in tension and compression.
6. Plane cross - sections remains plane before and after bending.

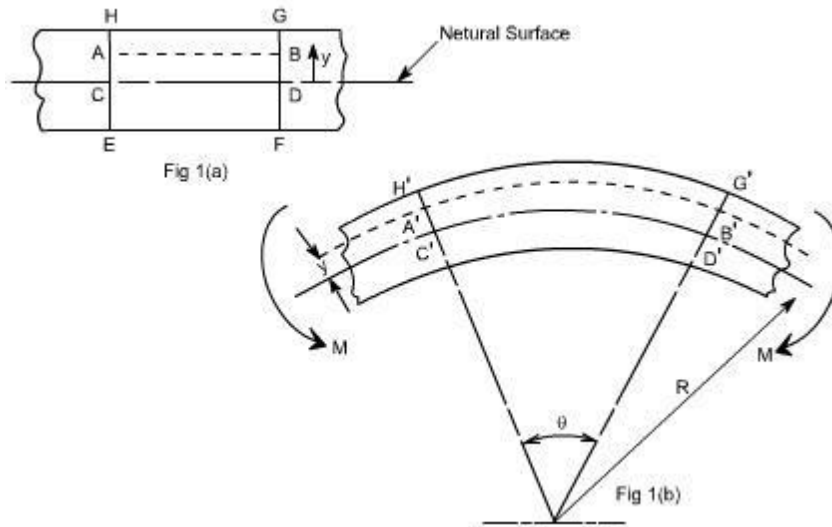

Let us consider a beam initially unstressed as shown in fig 1(a). Now the beam is subjected to a constant bending moment (i.e. 'Zero Shearing Force') along its length as would be obtained by applying equal couples at each end. The beam will bend to the radius R as shown in Fig 1(b)

As a result of this bending, the top fibers of the beam will be subjected to tension and the bottom to compression it is reasonable to suppose, therefore, **that some where between the two there are points at which the stress is zero. The locus of all such points is known as neutral axis** . The radius of curvature R is then measured to this axis. For symmetrical sections the N. A. is the axis of symmetry but what ever the section N. A. will always pass through the centre of the area or centroid.

The above restrictions have been taken so as to eliminate the possibility of 'twisting' of the beam.

Concept of pure bending:

Loading restrictions:

As we are aware of the fact internal reactions developed on any cross-section of a beam may consists of a resultant normal force, a resultant shear force and a resultant couple. In order to ensure that the bending effects alone are investigated, we shall put a constraint on the loading such that the resultant normal and the resultant shear forces are zero on any cross-section perpendicular to the longitudinal axis of the member,

That means $F = 0$

since $\frac{dM}{dx} = F = 0$ or $M = \text{constant}$.

Thus, the zero shear force means that the bending moment is constant or the bending is same at every cross-section of the beam. Such a situation may be visualized or envisaged when the beam or some portion of the beam, as been loaded only by pure couples at its ends. It must be recalled that the couples are assumed to be loaded in the plane of symmetry.

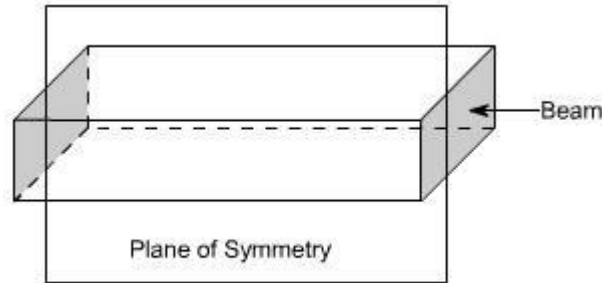

Fig (1)

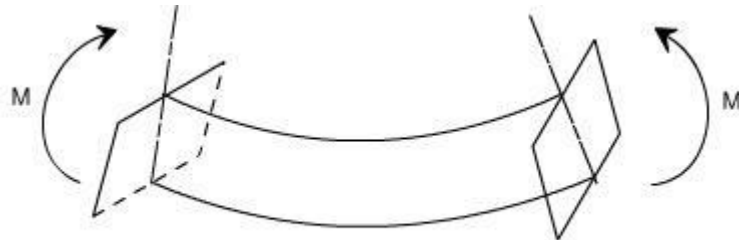

Fig (2)

When a member is loaded in such a fashion it is said to be in **pure bending**.

Bending Stresses in Beams or Derivation of Elastic Flexural formula :

In order to compute the value of bending stresses developed in a loaded beam, let us consider the two cross-sections of a beam **HE** and **GF** , originally parallel as shown in fig 1(a).when the beam is to bend it is assumed that these sections remain parallel i.e. **H'E'** and **G'F'** , the final position of the sections, are still straight lines, they then subtend some angle ϕ .

Consider now fiber **AB** in the material, at adistance y from the N.A, when the beam bends this will stretch to **A'B'**

Therefore ,

$$\text{strain in fibre AB} = \frac{\text{change in length}}{\text{original length}}$$

$$= \frac{A'B' - AB}{AB}$$

But $AB = CD$ and $CD = C'D'$

refer to fig1(a) and fig1(b)

$$\therefore \text{strain} = \frac{A'B' - C'D'}{C'D'}$$

Since **CD** and **C'D'** are on the neutral axis and it is assumed that the Stress on the neutral axis zero. Therefore, there won't be any strain on the neutral axis

$$= \frac{(R + y)\theta - R\theta}{R\theta} = \frac{R\theta + y\theta - R\theta}{R\theta} = \frac{y}{R}$$

However $\frac{\text{stress}}{\text{strain}} = E$ where $E = \text{Young's Modulus of elasticity}$

Therefore, equating the two strains as obtained from the two relations i.e.,

$$\frac{\sigma}{E} = \frac{y}{R} \text{ or } \frac{\sigma}{y} = \frac{E}{R} \quad \dots\dots\dots(1)$$

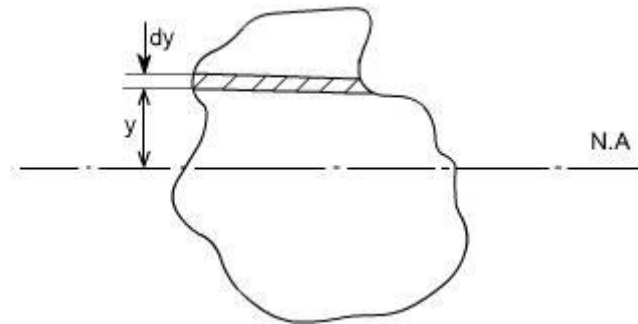

Consider any arbitrary a cross-section of beam, as shown above now the strain on a fibre at a distance 'y' from the N.A, is given by the expression

$$\sigma = \frac{E}{R} y$$

if the shaded strip is of area 'dA'
then the force on the strip is

$$F = \sigma \delta A = \frac{E}{R} y \delta A$$

$$\text{Moment about the neutral axis would be } = F \cdot y = \frac{E}{R} y^2 \delta A$$

The total moment for the whole cross-section is therefore equal to

$$M = \sum \frac{E}{R} y^2 \delta A = \frac{E}{R} \sum y^2 \delta A$$

Now the term $\sum y^2 \delta A$ is the property of the material and is called as a second moment of area of the cross-section and is denoted by a symbol I.

Therefore

$$M = \frac{E}{R} I \quad \dots\dots\dots(2)$$

combining equation 1 and 2 we get

$$\boxed{\frac{\sigma}{y} = \frac{M}{I} = \frac{E}{R}}$$

This equation is known as the Bending Theory Equation. The above proof has involved the assumption of pure bending without any shear force being present. Therefore this termed as the pure bending equation. This equation gives distribution of stresses which are normal to cross-section i.e. in x-direction.

Shearing Stresses in Beams

All the theory which has been discussed earlier, while we discussed the bending stresses in beams was for the case of pure bending i.e. constant bending moment acts along the entire length of the beam.

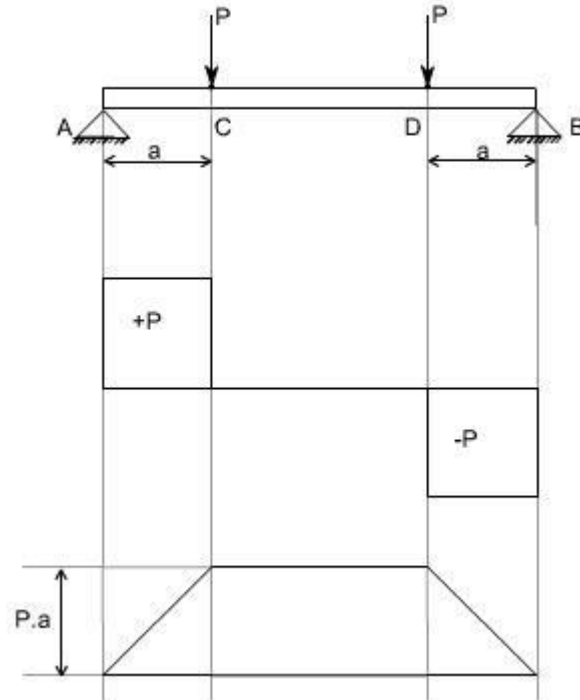

Let us consider the beam AB transversely loaded as shown in the figure above. Together with shear force and bending moment diagrams we note that the middle portion CD of the beam is free from shear force and that its bending moment, $M = P.a$ is uniform between the portion C and D. This condition is called the pure bending condition.

Since shear force and bending moment are related to each other $F = dM/dX$ (eq) therefore if the shear force changes then there will be a change in the bending moment also, and then this won't be the pure bending.

Conclusions :

Hence one can conclude from the pure bending theory was that the shear force at each X-section is zero and the normal stresses due to bending are the only ones produced.

In the case of non-uniform bending of a beam where the bending moment varies from one X-section to another, there is a shearing force on each X-section and shearing stresses are also induced in the material. The deformation associated with those shearing stresses causes “warping” of the x-section so that the assumption which we assumed while deriving the

relation $\frac{\sigma}{y} = \frac{M}{I} = \frac{E}{R}$ that the plane cross-section after bending remains plane is violated. Now due to warping the plane cross-section before bending do not remain plane after bending. This complicates the problem but more elaborate analysis shows that the normal stresses due to

bending, as calculated from the equation $\frac{\sigma}{y} = \frac{M}{I} = \frac{E}{R}$.

The above equation gives the distribution of stresses which are normal to the cross-section that is in x-direction or along the span of the beam are not greatly altered by the presence of these shearing stresses. Thus, it is justifiable to use the theory of pure bending in the case of non uniform bending and it is accepted practice to do so.

Let us study the shear stresses in the beams.

Concept of Shear Stresses in Beams :

By the earlier discussion we have seen that the bending moment represents the resultant of certain linear distribution of normal stresses σ over the cross-section. Similarly, the shear force F_x over any cross-section must be the resultant of a certain distribution of shear stresses.

Derivation of equation for shearing stress :

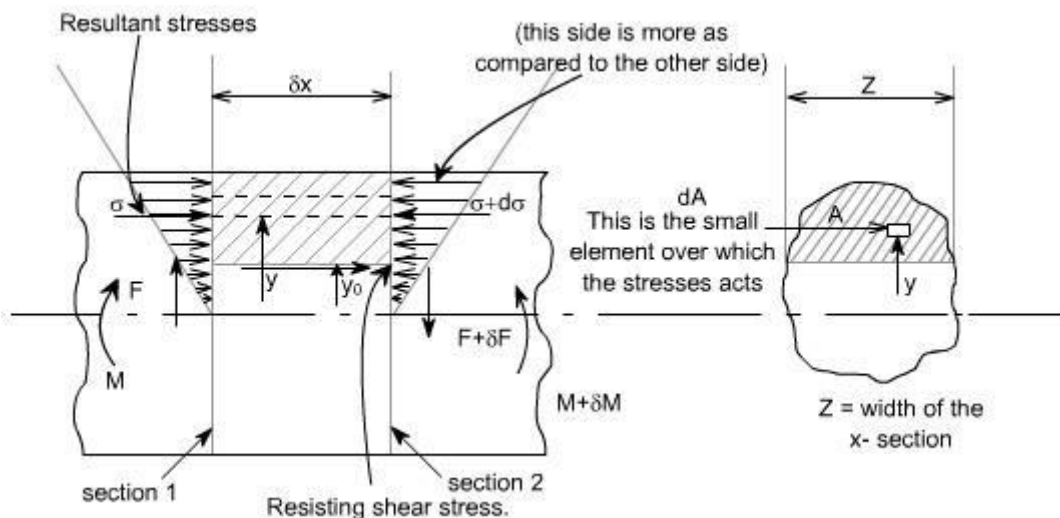

Assumptions :

1. Stress is uniform across the width (i.e. parallel to the neutral axis)
2. The presence of the shear stress does not affect the distribution of normal bending stresses.

It may be noted that the assumption no.2 cannot be rigidly true as the existence of shear stress will cause a distortion of transverse planes, which will no longer remain plane.

In the above figure let us consider the two transverse sections which are at a distance ' δx ' apart. The shearing forces and bending moments being F , $F + \delta F$ and M , $M + \delta M$ respectively. Now due to the shear stress on transverse planes there will be a complementary shear stress on longitudinal planes parallel to the neutral axis.

Let τ be the value of the complementary shear stress (and hence the transverse shear stress) at a distance ' y_0 ' from the neutral axis. Z is the width of the x-section at this position

A is area of cross-section cut-off by a line parallel to the neutral axis.

\bar{y} = distance of the centroid of Area from the neutral axis.

Let σ , $\sigma + d\sigma$ are the normal stresses on an element of area δA at the two transverse sections, then there is a difference of longitudinal forces equal to $(d\sigma \cdot \delta A)$, and this quantity summed over the area A is in equilibrium with the transverse shear stress τ on the longitudinal plane of area $z \delta x$.

$$\text{i.e. } \tau \cdot z \delta x = \int d\sigma \cdot dA$$

from the bending theory equation

$$\frac{\sigma}{y} = \frac{M}{I}$$

$$\sigma = \frac{M \cdot y}{I}$$

$$\sigma + d\sigma = \frac{(M + \delta M) \cdot y}{I}$$

$$\text{Thus } d\sigma = \frac{\delta M \cdot y}{I}$$

The figure shown below indicates the pictorial representation of the part.

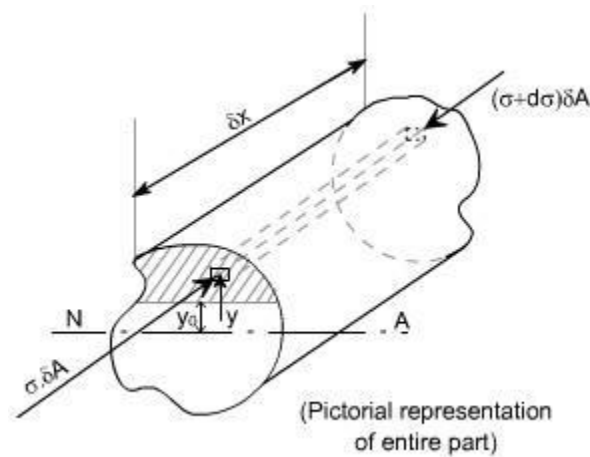

$$d\sigma = \frac{\delta M \cdot y}{I}$$

$$\begin{aligned} \tau \cdot z \delta x &= \int d\sigma \cdot dA \\ &= \int \frac{\delta M \cdot y \cdot \delta A}{I} \end{aligned}$$

$$\tau \cdot z \delta x = \frac{\delta M}{I} \int y \cdot \delta A$$

$$\text{But } F = \frac{\delta M}{\delta x}$$

$$\text{i.e. } \tau = \frac{F}{l \cdot z} \int y \cdot \delta A$$

$$\text{But from definition, } \int y \cdot dA = A \bar{y}$$

$\int y \cdot dA$ is the first moment of area of the shaded portion

and \bar{y} = centroid of the area 'A'

Hence

$$\tau = \frac{F \cdot A \cdot \bar{y}}{l \cdot z}$$

So substituting

Where 'z' is the actual width of the section at the position where 'στ' is being calculated and I is the total moment of inertia about the neutral axis.

Bending of Composite or Flitched Beams:

A composite beam is defined as the one which is constructed from a combination of materials. If such a beam is formed by rigidly bolting together two timber joists and a reinforcing steel plate, then it is termed as a flitched beam.

The bending theory is valid when a constant value of Young's modulus applies across a section it cannot be used directly to solve the composite-beam problems where two different materials, and therefore different values of E, exists. The method of solution in such a case is to replace one of the materials by an equivalent section of the other.

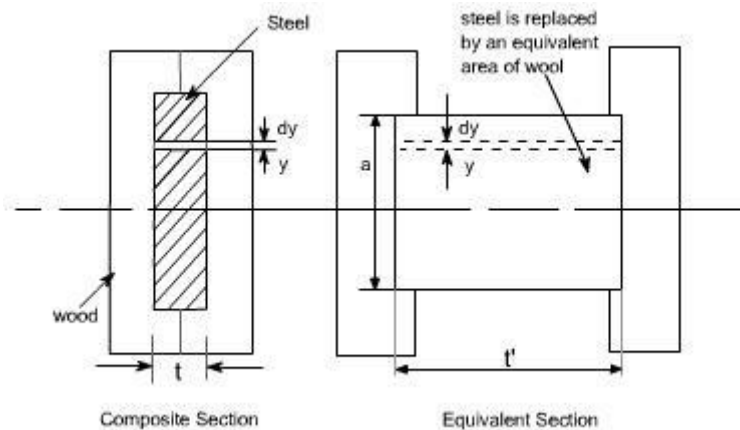

Consider, a beam as shown in figure in which a steel plate is held centrally in an appropriate recess/pocket between two blocks of wood .Here it is convenient to replace the steel by an equivalent area of wood, retaining the same bending strength. i.e. the moment at any section must be the same in the equivalent section as in the original section so that the force at any given dy in the equivalent beam must be equal to that at the strip it replaces.

$$\sigma \cdot t = \sigma' \cdot t' \text{ or } \boxed{\frac{\sigma}{\sigma'} = \frac{t'}{t}}$$

recalling $\sigma = E \cdot \varepsilon$

Thus

$$\varepsilon E t = \varepsilon' E' t'$$

Again, for true similarity the strains must be equal,

$$\varepsilon = \varepsilon' \text{ or } E t = E' t' \text{ or } \boxed{\frac{E}{E'} = \frac{t'}{t}}$$

Thus, $\boxed{t' = \frac{E}{E'} \cdot t}$

Hence to replace a steel strip by an equivalent wooden strip the thickness must be multiplied by the modular ratio E/E'.

The equivalent section is then one of the same materials throughout and the simple bending theory applies. The stress in the wooden part of the original beam is found directly and that in the steel found from the value at the same point in the equivalent material as follows by utilizing the given relations.

$$\frac{\sigma}{\sigma} = \frac{t}{t}$$

$$\frac{\sigma}{\sigma} = \frac{E}{E}$$

Stress in steel = modular ratio x stress in equivalent wood

The above procedure of course is not limited to the two materials treated above but applies well for any material combination. The wood and steel flitched beam was nearly chosen as a just for the sake of convenience.

Assumption

In order to analyze the behavior of composite beams, we first make the assumption that the materials are bonded rigidly together so that there can be no relative axial movement between them. This means that all the assumptions, which were valid for homogenous beams are valid except the one assumption that is no longer valid is that the Young's Modulus is the same throughout the beam.

The composite beams need not be made up of horizontal layers of materials as in the earlier example. For instance, a beam might have stiffening plates as shown in the figure below.

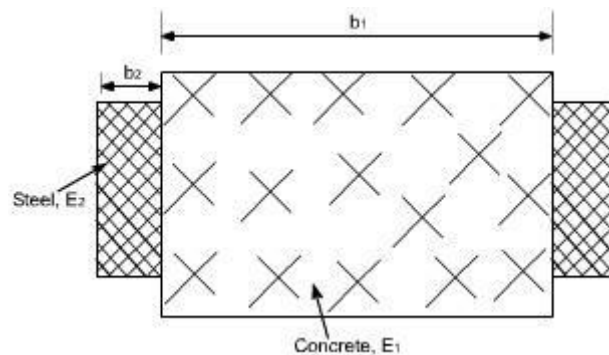

Again, the equivalent beam of the main beam material can be formed by scaling the breadth of the plate material in proportion to modular ratio. Bearing in mind that the strain at any level is same in both materials, the bending stresses in them are in proportion to the Young's modulus.

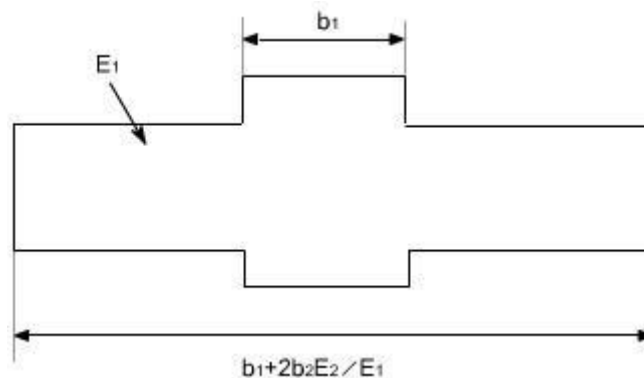

A cantilever 6m long carries load of 30, 70, 40 and 60kN at a distance of 0, 0.6, 1.5 and 2.4m respectively from the free end. Draw the shear force and bending moment diagrams for the cantilever beam

Solution:

SF calculation:

$$\text{SF at E} = 30 \text{ kN}$$

$$\begin{aligned} \text{SF at D} &= 30 + 70 \\ &= 100 \text{ kN} \end{aligned}$$

$$\begin{aligned} \text{SF at C} &= 100 + 40 \\ &= 140 \text{ kN} \end{aligned}$$

$$\begin{aligned} \text{SF at B} &= 140 + 60 \\ &= 200 \text{ kN} \end{aligned}$$

$$\text{SF at A} = 200 \text{ kN}$$

Join all the values by straight horizontal line as shown in Fig. (b).

BM calculation:

$$\text{BM at E} = 0$$

$$\text{BM at D} = -30 \times 0.6 = -18 \text{ kN-m}$$

$$\text{BM at C} = -30 \times 1.5 - 70 \times 0.9 = -108 \text{ kN-m}$$

$$\text{BM at B} = -30 \times 2.4 - 70 \times 1.8 - 40 \times 0.9 = -234 \text{ kN-m}$$

$$\begin{aligned} \text{BM at A} &= -30 \times 6 - 70 \times 5.4 - 40 \times 4.5 - 60 \times 3.6 \\ &= -954 \text{ kN-m} \end{aligned}$$

Join all the values by straight inclined lines as shown in Fig. (c).

Result: The SFD and BMD are as shown in Fig (b) & (c) respectively.

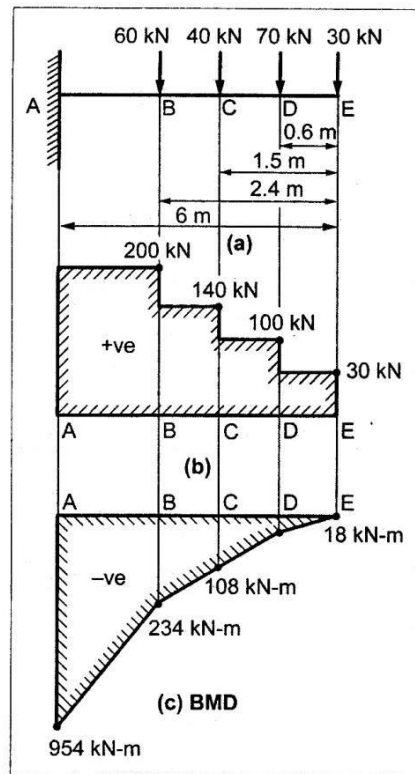

In this there is an abrupt change of loading beyond a certain point thus, we shall have to be careful at the jumps and the discontinuities.

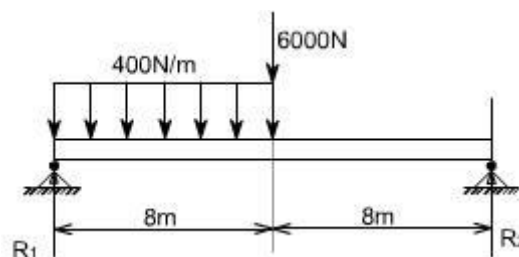

For the given problem, the values of reactions can be determined as

$$R_2 = 3800\text{N and } R_1 = 5400\text{N}$$

The shear force and bending moment diagrams can be drawn by considering the X-sections at the suitable locations.

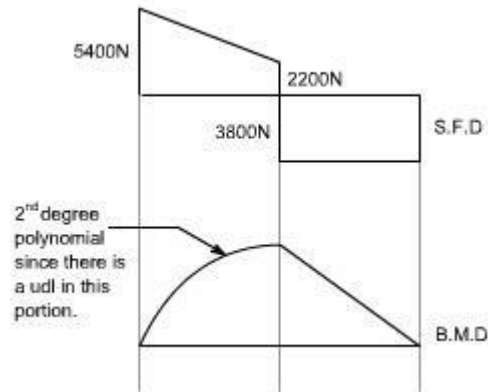

A simply supported beam of rectangular cross section 60 x 35 mm and 3m long carrying a load of 5kN at mid span. Determine the maximum bending stress induced in the beam.

Given:

Simply supported beam,

Breadth, $b = 60 \text{ mm}$

Height, $h = 35 \text{ mm}$

Length, $l = 3 \text{ m}$

Load, $W = 5 \text{ kN}$

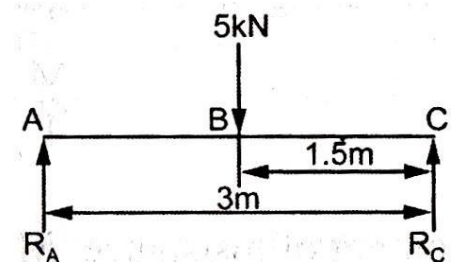

To find: Maximum bending stress, σ_b .

☺ Solution:

Bending moment, M at centre:

Taking moment about A,

$$R_C \times 3 \text{ m} = 5 \times 1.5$$

$$R_C = \frac{7.5}{3} = 2.5 \text{ m}$$

$$R_A + R_C = 5 \text{ kN}$$

$$R_A = 5 - 2.5 = 2.5 \text{ kN}$$

Taking moment about B,

$$M = R_C \times 1.5$$

$$= 2.5 \times 1.5$$

$$= 3.75 \text{ kN-m}$$

$$= 3.75 \times 10^6 \text{ N-mm}$$

Moment of inertia for rectangular section, $I = \frac{bh^3}{12} = \frac{60 \times 35^3}{12}$
 $= 214375 \text{ mm}^4$

Maximum bending stress will occur at centre of the height of the beam

$$\therefore y = \frac{35}{2} = 17.5 \text{ mm}$$

From the theory of simple bending equation

$$\frac{M}{I} = \frac{\sigma_b}{y} \Rightarrow \sigma_b = \frac{M}{I} \times y$$

$$\sigma_b = \frac{3.75 \times 10^6}{214375} \times 17.5$$

$$= 306.12 \text{ N/mm}^2$$

$$= 306.12 \text{ N/mm}^2$$

Result:

Maximum bending stress, $\sigma_{bmax} = 306.12 \text{ N/mm}^2$

UNIT-III

TORSION

3.1 Torsion of Circular Shafts

a. Simplifying assumptions

During the deformation, the cross sections are not distorted in any manner they remain plane, and the radius r does not change. In addition, the length L of the shaft remains constant.

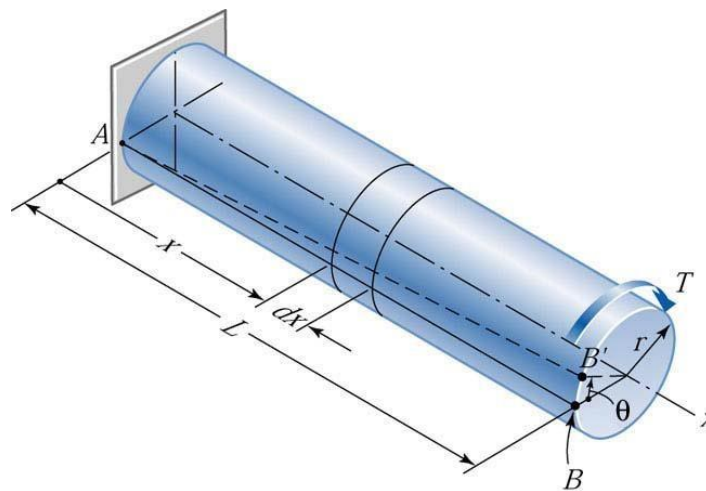

Figure 3.1

Deformation of a circular shaft caused by the torque T . The initially straight line AB deforms into a helix.

Based on these observations, we make the following

Assumptions:

- Circular cross sections remain plane (do not warp) and perpendicular to the axis of the shaft.
- Cross sections do not deform (there is no strain in the plane of the cross section).
- The distances between cross sections do not change (the axial normal strain is zero).

Each cross section rotates as a rigid entity about the axis of the shaft. Although this conclusion is based on the observed deformation of a cylindrical shaft carrying a constant internal torque,

we assume that the result remains valid even if the diameter of the shaft or the internal torque varies along the length of the shaft.

b. Compatibility

Because the cross sections are separated by an infinitesimal distance, the difference in their rotations, denoted by the angle $d\theta$, is also infinitesimal.

As the cross sections undergo the relative rotation $d\theta$, CD deforms into the helix CD . By observing the distortion of the shaded element, we recognize that the helix angle γ is the *shear strain* of the element.

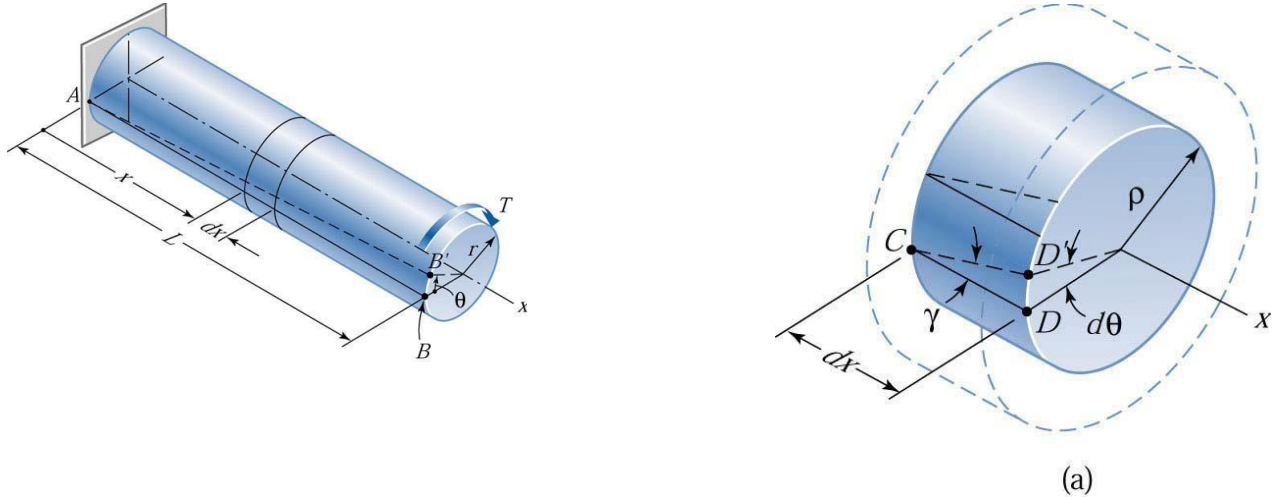

From the geometry of Fig.3.2(a), we obtain $DD' = \rho d\theta = \gamma dx$, from which the shear strain γ is

$$\gamma = \frac{d\theta}{dx} \rho \quad (3.1)$$

The quantity $d\theta/dx$ is the *angle of twist per unit length*, where θ is expressed in radians. The corresponding shear stress, illustrated in Fig. 3.2 (b), is determined from Hooke's law:

(3.2)

$$\tau = G\gamma = G \frac{d\theta}{dx} \rho$$

strain of a material element caused by twisting of the shaft;

(b) the corresponding shear stress.

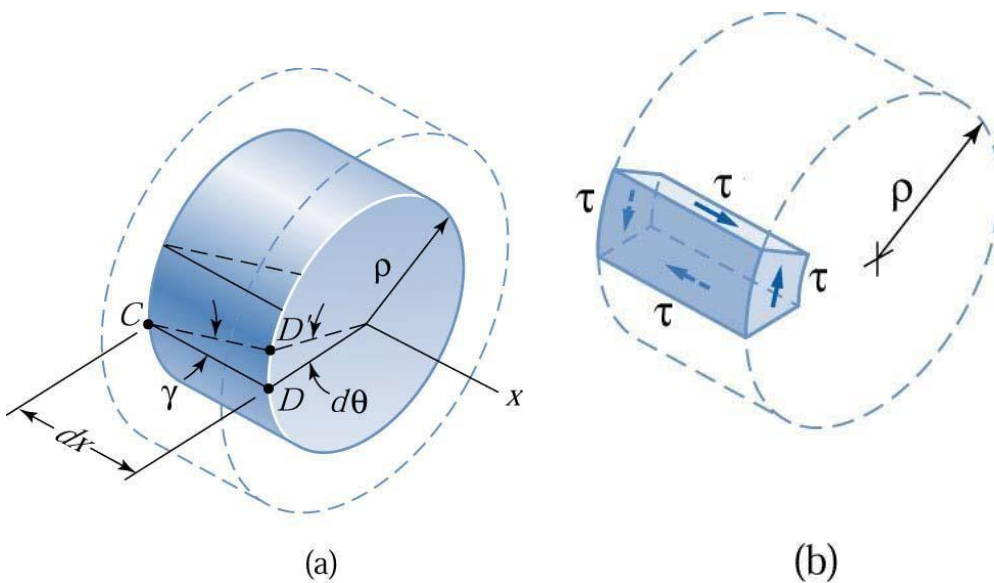

the shear stress varies linearly with the radial distance ρ from the axial of the shaft.

$$r = G\gamma = G \frac{d\theta}{dx} \rho$$

The variation of the shear stress acting on the cross section is illustrated in Fig. 3.3. The maximum shear stress, denoted by τ_{\max} , occurs at the surface of the shaft.

Note that the above derivations assume neither a constant internal torque nor a constant cross section along the length of the shaft.

Figure 3.3 Distribution of shear stress along the radius of a circular shaft.

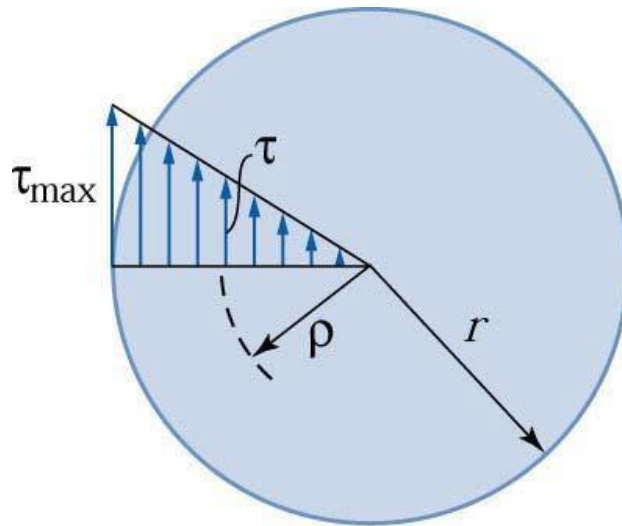

Fig. 3.4 shows a cross section of the shaft containing a differential element of area dA loaded at the radial distance ρ from the axis of the shaft.

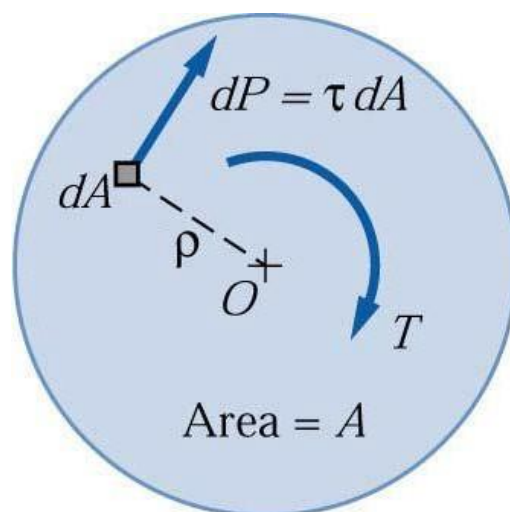

Figure 3.4 Calculating the Resultant of the shear stress acting on the cross section. Resultant is a couple equal to the internal torque T .

The shear force acting on this area is $dP = \tau dA = G (d\theta/dx) \rho dA$, directed perpendicular to the radius. Hence, the moment (torque) of dP about the center o is $\rho dP = G (d\theta/dx) \rho dA$. Summing the contributions and equating the result to the internal torque yields.

$$\int \rho dP = T$$

$$G \frac{d\theta}{dx} \int \rho^2 dA = T$$

Recognizing that is the polar moment of inertia of the crosssectional area, we can write this equation as $G (d\theta/dx) J = T$, or

$$\frac{d\theta}{dx} = \frac{T}{GJ}$$

The rotation of the cross section at the free end of the shaft, called **the angle of twist** θ , is obtained by integration:

$$\theta = \int_0^L d\theta = \int_0^L \frac{T}{GJ} dx$$

As in the case of a **prismatic bar** carrying a constant torque, then reduces **the torque-twist relationship**

$$\theta = \frac{TL}{GJ}$$

$G (d\theta/dx) = T/J$, which substitution into Eq. (3.2),

$$r = G\gamma = G \frac{d\theta}{dx} \rho$$

gives the shear stress τ acting at the distance ρ from the center of the shaft, **Torsion formulas**

$$r = \frac{T\rho}{J}$$

The **maximum** shear stress τ_{max} is found by replacing ρ by the radius r of the shaft:

$$r_{max} = \frac{Tr}{J}$$

Because Hook's law was used in the derivation of Eqs. (3.2)- (3.5), these formulas are valid if the shear stresses do not exceed the proportional limit of the material shear. Furthermore, these formulas are applicable only to **circular shafts**, either solid or hollow.

The expressions for the polar moments of circular areas are

Solid shaft

$$r_{max} = \frac{2T}{\pi r^3} = \frac{16T}{\pi d^3}$$

Hollow shaft

$$r_{max} = \frac{2T}{\pi(R^4 - r^4)} = \frac{16T}{\pi(D^4 - d^4)}$$

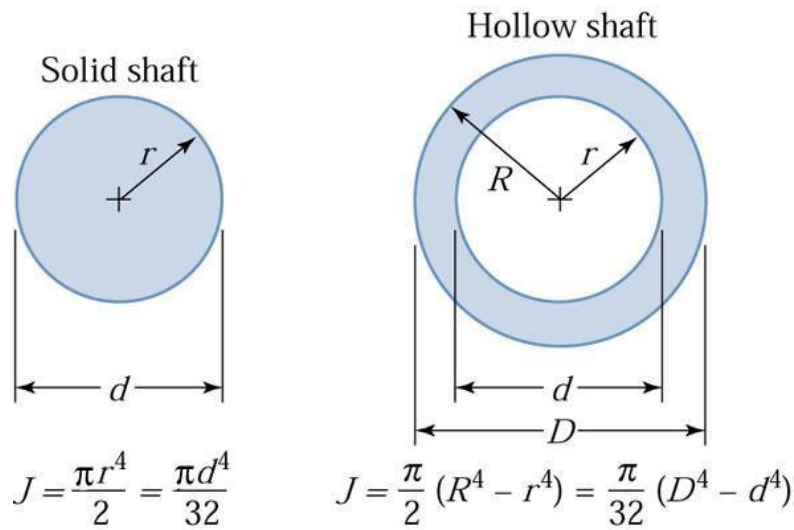

Figure 3.6 Polar moments of inertia of circular areas.

Shafts are used to transmit power. The power ζ transmitted by a torque T rotating at the angular speed ω is given by $\zeta = T \omega$, where ω is measured in radians per unit time.

If the shaft is rotating with a frequency of f revolutions per unit time, then $\omega = 2\pi f$, which gives $\zeta = T (2\pi f)$. Therefore, the torque can be expressed as

$$T = \frac{\zeta}{2\pi f}$$

Composite shafts: (in series)

If two or more shaft of different material, diameter or basic forms are connected together in such a way that each carries the same torque, then the shafts are said to be connected in series & the composite shaft so produced is therefore termed as series – connected.

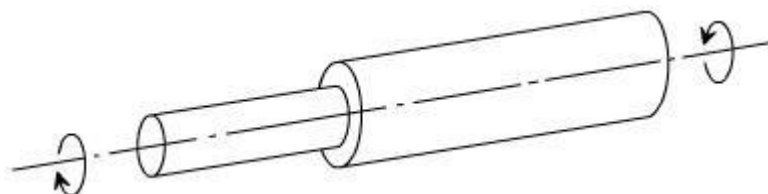

Here in this case the equilibrium of the shaft requires that the torque 'T' be the same through out both the parts.

In such cases the composite shaft strength is treated by considering each component shaft separately, applying the torsion – theory to each in turn. The composite shaft will therefore be as weak as its weakest component. If relative dimensions of the various parts are required then a solution is usually effected by equating the torque in each shaft e.g. for two shafts in series

$$T = \frac{G_1 J_1 \theta_1}{L_1} = \frac{G_2 J_2 \theta_2}{L_2}$$

In some applications it is convenient to ensure that the angle of twist in each shaft are equal

i.e. $\theta_1 = \theta_2$, so that for similar materials in each shaft $\frac{J_1}{L_1} = \frac{J_2}{L_2}$ or $\frac{L_1}{L_2} = \frac{J_1}{J_2}$

The total angle of twist at the free end must be the sum of angles $\theta_1 =$

Composite shaft parallel connection: If two or more shafts are rigidly fixed together such that the applied torque is shared between them then the composite shaft so formed is said to be connected in parallel.

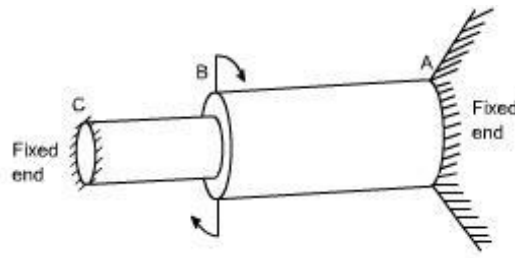

For parallel connection.

$$\text{Total Torque } T = T_1 + T_2$$

In this case the angle of twist for each portion are equal and $\frac{T_1 L_1}{G_1 J_1} = \frac{T_2 L_2}{G_2 J_2}$

for equal lengths(as is normaly the case for parallel shafts) $\frac{T_1}{T_2} = \frac{G_1 J_1}{G_2 J_2}$

This type of configuration is statically indeterminate, because we do not know how the applied torque is apporioned to each segment, To deal such type of problem the procedure is exactly the same as we have discussed earlier,

Thus two equations are obtained in terms of the torques in each part of the composite shaft and the maximun shear stress in each part can then be found from the relations.

$$\tau_1 = \frac{T_1 R_1}{J_1}$$

$$\tau_2 = \frac{T_2 R_2}{J_2}$$

A solid circular shaft is required transmit 95kW at 150rpm. Find out the diameter of the shaft if permissible shear stress is 60MPa and angle of twist is 0.3° per meter length. Take C= 1 x 10⁵ N/mm².

Given Data

- P = 95 kW
- N = 150 rpm
- $\theta = 0.3^\circ \times \frac{\pi}{180} = 5.2 \times 10^{-3} \text{ rad}$
- l = 1 m
- $\tau = 60 \text{ MPa} = 60 \text{ N/mm}^2$
- C = 1 x 10⁵ N/mm²

soln.

$$P = \frac{2\pi NT}{60}$$

$$95 = \frac{2\pi \times 150 \times T}{60}$$

$$T = 6.04 \text{ kN-m} = 6.04 \times 10^6 \text{ N-mm}$$

case i) Considering shear stress (τ)

$$T = \frac{\pi}{16} \cdot \tau \times D^3$$

$$6.04 \times 10^6 = \frac{\pi}{16} \times 60 \times D^3$$

$$\boxed{D = 80 \text{ mm}}$$

case ii) Considering angle of twist (θ)

$$\frac{T}{J} = \frac{C\theta}{l}$$

$$\frac{6.04 \times 10^6}{\frac{\pi}{32} D^4} = \frac{1 \times 10^5 \times 5.2 \times 10^{-3}}{1000}$$

$$\boxed{D = 104.2 \text{ mm}}$$

subable diameter is 104.02 mm.

A hollow shaft with diameter ratio $\frac{3}{5}$ is required transmit 450 kW at 120rpm. The shearing stress in the shaft must not exceed 60 N/mm² and the twist in a length of 2.5 m is not to exceed 1°. Calculate the minimum external diameter of the shaft. $C = 80 \text{ N/mm}^2$.

Given Data

$$P = 450 \text{ kW}$$

$$N = 120 \text{ rpm}$$

$$\tau = 60 \text{ N/mm}^2$$

$$l = 2.5 \text{ m} = 2500 \text{ mm}$$

$$\theta = 1^\circ \times \frac{\pi}{180} = 0.01745$$

$$C = 80 \text{ N/mm}^2$$

$$\frac{d}{D} = \frac{3}{5} \Rightarrow D = 1.66d$$

$$d = 0.6D$$

soln

$$P = \frac{2\pi NT}{60}$$

$$450 = \frac{2\pi \times 120 \times T}{60}$$

$$T = 35.80 \text{ kN-m} = 35.80 \times 10^6 \text{ N-mm}$$

$$\text{Case i) } T = \frac{\pi}{16} \cdot \tau \cdot \frac{D^4 - d^4}{D}$$

$$35.80 \times 10^6 = \frac{\pi}{16} \times 60 \cdot \frac{D^4 - (0.6D)^4}{D}$$

$$D = 151.70 \text{ mm}$$

$$\text{Case ii) } \frac{\tau}{J} = \frac{C\theta}{l}$$

$$\frac{35.80 \times 10^6}{\frac{\pi}{32} (D^4 - d^4)} = \frac{80 \times 0.01745}{2500}$$

$$D = 930.68 \text{ mm}$$

Suitable diameter $D = 930.68 \text{ mm}$

$$d = 558.408 \text{ mm}$$

A hollow shaft having an inside diameter 60% of its outer diameter, is to replace a solid shaft transmitting in the same power at the same speed. Calculate percentage saving in material, if the material to be is also the same.

$$D_i = 0.6 D_o$$

Power by solid or hollow shaft $P = \frac{2\pi NT}{60}$

$$T = \frac{60 \times P}{2\pi N}$$

Torque transmitted by solid shaft $T = \frac{\pi}{16} \tau D^3$ — (1)

Torque transmitted by hollow shaft $T = \frac{\pi}{16} \tau \left[\frac{D_o^4 - D_i^4}{D_o} \right]$

$$\left\{ D_i = 0.6 D_o \right\}$$

$$\therefore T = \frac{\pi}{16} \cdot \tau \times 0.8704 D_o^3$$
 — (2)

equating (1) & (2) : we get

$$D = 0.9548 D_o$$

Saving in material = $\frac{\text{Area of solid shaft} - \text{Area of hollow shaft}}{\text{Area of solid shaft}}$

$$= \frac{\frac{\pi}{4} D^2 - \frac{\pi}{4} (D_o^2 - D_i^2)}{\frac{\pi}{4} D^2}$$

$$= \frac{0.716 D_o^2 - 0.502 D_o^2}{0.716 D_o^2}$$

$$= 0.2988$$

percentage saving in material = $0.2988 \times 100 = 29.88\%$

Design a suitable diameter for a shaft required to transmit 120KW at 180 rpm. The shear stress in the shaft not to exceed 70N/mm² and the maximum torque exceeds the mean by 40%. Calculate the angle of twist in a length of 2m. Take C = 0.8 x 10⁵ N/mm².

Given data:

$$P = 120 \text{ kW}$$

$$N = 180 \text{ rpm}$$

$$\tau = 70 \text{ N/mm}^2$$

$$l = 2 \text{ m} = 2000 \text{ mm}$$

$$T_{max} = 1.4 T_{mean}$$

$$C = 0.8 \times 10^5 \text{ N/mm}^2$$

To find: Angle of twist (θ)

☺**Solution:** We know that,

$$\text{Power, } P = \frac{2\pi NT}{60}$$

$$120 = \frac{2 \times \pi \times 180 \times T}{60}$$

$$\begin{aligned} T &= 6.36 \text{ kN-m} \\ &= 6.36 \times 10^3 \text{ N-m} \\ &= 6.36 \times 10^6 \text{ N-mm} \end{aligned}$$

$$T = T_{\text{mean}} = 6.36 \times 10^6 \text{ N-mm}$$

We know that,

$$T_{\text{max}} = 1.4 T_{\text{mean}} = 1.4 \times 6.36 \times 10^6$$

$$T_{\text{max}} = 8.912 \times 10^6 \text{ N-mm}$$

We know that,

$$\text{Torque, } T = \frac{\pi}{16} \times \tau \times D^3$$

$$8.91 \times 10^6 = \frac{\pi}{16} \times 70 \times D^3$$

$$\text{Shaft diameter, } D = 86.54 \text{ mm}$$

Consider angle of twist,

$$\frac{T}{J} = \frac{C\theta}{l} \quad \dots (1)$$

Where, J (polar moment of inertia) = $\frac{\pi}{32} (D)^4$

$$(1) \Rightarrow \frac{8.912 \times 10^6}{\frac{\pi}{32} \times D^4} = \frac{0.8 \times 10^5 \times \theta}{2000}$$

$$\frac{8.912 \times 10^6}{\frac{\pi}{32} \times (86.54)^4} = \frac{0.8 \times 10^5 \times \theta}{2000}$$

\Rightarrow

$$\theta = 0.040 \text{ rad}$$

$$\theta = 0.040 \times \frac{180}{\pi} = 2.3'$$

$$\text{Angle of twist, } \theta = 2.3^\circ$$

Result: Angle of twist, $\theta = 2.3^\circ$

Stresses in Helical Springs of Circular Wire

- D = Mean diameter of the spring coil,
- d = Diameter of the spring wire,
- n = Number of active coils,
- G = Modulus of rigidity for the spring material,
- W = Axial load on the spring,
- τ = Maximum shear stress induced in the wire,
- C = Spring index = D/d ,
- ρ = Pitch of the coils, and
- δ = Deflection of the spring, as a result of an axial load W .

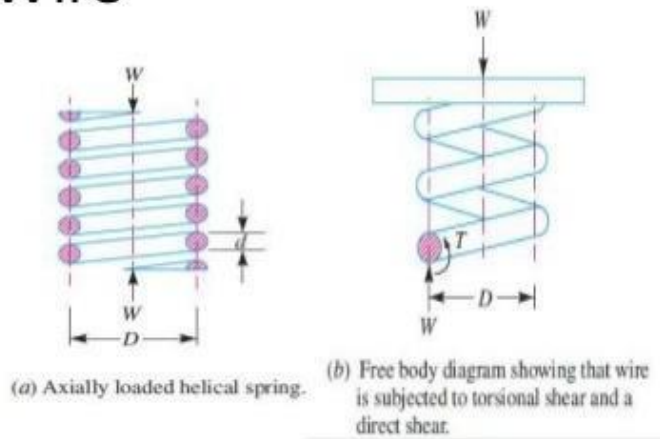

The elongation of the bar is

$$\delta = \frac{64WR^3n}{Cd^4}$$

Notice that the deformation δ is directly proportional to the applied load P . The ratio of P to δ is called the [spring constant](#) k and is equal to

$$K = \frac{W}{\delta} = \frac{Cd^4}{64R^3n}$$

Springs in Series

For two or more springs with spring laid in series, the resulting spring constant k is given by

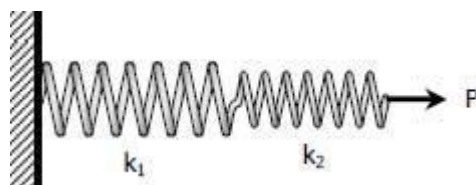

$$\frac{1}{K} = \frac{1}{K_1} + \frac{1}{K_2} + \dots \dots \dots$$

Springs in Parallel

For two or more springs in parallel, the resulting spring constant is

A close coiled helical spring is to have a stiffness of 1.5 N/mm of compression under a maximum load of 60 N and maximum shearing stress of 125 N/mm². The solid length of the spring (ie., when the coils are touching) is to be 50 mm. Find the diameter of the wire, mean diameter of the coil and no. of coil required. Take $C = 4.5 \times 10^4$ N/mm².

$$\text{Stiffness } k = \frac{C d^4}{64 R^3 n}$$

$$1.5 = \frac{4.5 \times 10^4 d^4}{64 R^3 n}$$

$$2.133 \times 10^{-3} = \frac{d^4}{R^3 n} \quad \text{--- (1)}$$

$$\text{Shear stress } \tau = \frac{8WD}{\pi d^3} = \frac{16WR}{\pi d^3}$$

$$125 = \frac{16 \times 60 \times R}{\pi d^3}$$

$$0.4090 = \frac{R}{d^3} \quad \text{we know } nd = 50 \quad \text{--- (2)}$$

sub d value in eqn (1) & (2)

$$R^3 n^5 = 2.930 \times 10^9 \quad \text{--- (3)}$$

$$R = \frac{5.1125 \times 10^3}{n^3} \quad \text{--- (4)}$$

sub R value

$$\left(\frac{5.1125 \times 10^3}{n^3} \right)^3 n^5 = 2.930 \times 10^9$$

$$n = 14.62 = 15$$

$$\text{Diameter of coil } D = 82.72 \text{ mm}$$

$$\text{Diameter of wire } d = 3.42 \text{ mm}$$

OR

Derive the relation for deflection of a closely coiled helical spring subjected to an axial downward load W.

$$T = W \times R$$

$$\frac{T}{J} = \frac{C\theta}{l} \Rightarrow \theta = \frac{Tl}{cJ} = \frac{WR \times 2\pi R n}{c \cdot \frac{\pi}{32} d^4}$$

$$\left\{ T = WR, l = 2\pi R n, J = \frac{\pi}{32} d^4 \right\}$$

$$\theta = \frac{64WR^2n}{cd^4}$$

$$\text{Deflection } \delta = R \cdot \theta = R \times \frac{64WR^2n}{cd^4}$$

$$\delta = \frac{64WR^3n}{cd^4}$$

$$\text{Stiffness } k = \frac{W}{\delta} = \frac{W}{\frac{64WR^3n}{cd^4}}$$

$$k = \frac{cd^4}{64R^3n}$$

$$\frac{T}{J} = \frac{\tau}{Y} \Rightarrow \tau = \frac{T}{J} \cdot Y = \frac{WR}{\frac{\pi d^4}{32}} \times \frac{d}{2}$$

$$\text{Shear stress } \tau = \frac{16WR}{\pi d^3} \quad \text{or } \tau = \frac{8WD}{\pi d^3}$$

The amount of energy stored in the spring

$$\begin{aligned} U &= \frac{1}{2} T \theta = \frac{1}{2} WR \times \frac{Tl}{cJ} \\ &= \frac{1}{2} WR \times \frac{WR \times l}{c \left(\frac{\pi d^4}{32} \right)} = \frac{16^2 W^2 R^2}{\pi^2 d^6} \times \frac{\pi d^2 l}{4 \times 4c} \\ U &= \frac{\tau^2}{4c} \times \left(\frac{\pi d^2}{4} \times l \right) \end{aligned}$$

A closely coiled helical spring of mean diameter 20cm is made of 3cm diameter rod and has 16 turns. A weight of 3kN is dropped on this spring. Find the height by which the weight should be dropped before striking the spring so that the spring may be compressed by 18cm. Take $C = 8 \times 10^4 \text{ N/mm}^2$.

$$\text{Deflection } \delta = \frac{6AWR^3n}{cd^4}$$

$$180 = \frac{6A \times W \times 100^3 \times 16}{8 \times 10^4 \times 30^4}$$

$$W = 11390 \text{ N}$$

Work done by the falling weight on spring

$$= \text{weight} \times \text{falling} (h + \delta)$$

$$= 3000 (h + 180) \quad \text{--- (1)}$$

Energy stored in the spring

$$= \frac{1}{2} W \times \delta$$

$$= \frac{1}{2} \times 11390 \times 180$$

$$= 1025100 \text{ Nmm} \quad \text{--- (2)}$$

Equating (1) & (2) :

$$3000 (h + 180) = 1025100$$

$$h = 341.7 \text{ mm}$$

In open coiled helical spring consists of 12 coils, the stress due to bending and twisting are 75 MPa and 92 MPa respectively. When the spring is axially loaded, find the maximum permissible load and diameter of wire for a maximum extension of 25mm. Assume spring index as 9. Take $E = 210 \text{ GPa}$ and $C = 80 \text{ GPa}$.

$$\text{Axial deflection } \delta = \frac{6AWR^3n \sec \alpha}{d^4} \left[\frac{\cos^2 \alpha}{C} + \frac{2 \sin^2 \alpha}{E} \right] \quad \text{--- (1)}$$

$$\text{shear stress } \tau = \frac{16WR \cos \alpha}{\pi d^3}$$

$$92 = \frac{16WR \cos \alpha}{\pi d^3} \quad \text{--- (2)}$$

$$\text{Bending stress } \sigma_b = \frac{32WR \sin \alpha}{\pi d^3}$$

$$75 = \frac{32WR \sin \alpha}{\pi d^3} \quad \text{--- (3)}$$

eqn ③ ÷ eqn ②,

$$\frac{75}{92} = 2 \tan \alpha$$

$$\alpha = 22^\circ 10'$$

Sub in eqn ②:

$$92 = \frac{16 W \times 4.5 d \cos 22^\circ 10'}{\pi d^3}$$

Sub these value in eqn ①.

$$d = 6.35 \text{ mm}$$

$$W = 4.33 d^2$$

$$W = 174.59 \text{ N}$$

A closed coil helical spring made out of 8mm diameter wire has 18 coils. Each coil is of 80mm mean diameter. If the maximum allowable stress in the spring is 140Mpa, determine the allowable load on the spring, elongation of the spring and stiffness of the spring. Take $C = 82 \text{ KN/mm}^2$

Given data:

$$d = 8 \text{ mm}$$

$$n = 18$$

$$D = 80 \text{ mm}$$

$$\tau = 140 \text{ Mpa} = 140 \times 10^6 \text{ N/m}^2 = 140 \text{ N/mm}^2$$

$$C = 82 \text{ kN/mm}^2 = 82 \times 10^3 \text{ N/mm}^2$$

To find: (i) W

(ii) δ

(iii) K

☺**Solution:** We know that shear stress of the closed coil helical spring

$$\tau = \frac{8 W D}{\pi d^3}$$

$$140 = \frac{8 \times W \times 80}{\pi (8)^3}$$

$$\therefore W = \frac{140 \times \pi \times 8^3}{8 \times 80} = 351.86 \text{ N}$$

Deflection of the spring

$$\delta = \frac{8 W D^3 n}{C d^4}$$

$$= \frac{8 \times 351.86 \times 80^3 \times 18}{82 \times 10^3 \times 8^4} = 77.24 \text{ mm}$$

Stiffness of the spring

$$K = \frac{W}{\delta}$$

$$= \frac{351.86}{77.24} = 4.55 \text{ N/mm}$$

Result:

Allowable load on the spring, $W = 351.86 \text{ N}$

Deflection of the spring, $\delta = 77.24 \text{ mm}$

Stiffness of the spring, $K = 4.55 \text{ N/mm}$

A laminated spring carries a central load of 5200N and it is made of 'n' number of plates, 80mm wide, 7mm thick and length 500mm. Find the number of plates, if the maximum deflection is 10mm. Let $E = 2 \times 10^5 \text{ N/mm}^2$

Given:

$$W = 5200 \text{ N}$$

$$b = 80 \text{ mm}$$

$$t = 7 \text{ mm}$$

$$L = 500 \text{ mm}$$

$$d = 10 \text{ mm}$$

$$E = 2 \times 10^5 \text{ N/mm}^2$$

w.k.t stress,

$$\sigma = \frac{3Wl}{2nbt^2}$$

$$\sigma = \frac{3 \times 5200 \times 500 \times 10^{-3}}{2n \times 80 \times 10^{-3} (7 \times 10^{-3})^2}$$

$$\sigma = \frac{994.89 \times 10^6}{n}$$

The equation for deflection is,

$$\delta = \frac{\sigma l^2}{4Et}$$

$$10 \times 10^{-3} = \frac{994.89 \times 10^6 \times (500 \times 10^{-3})^2}{n \times 4 \times 2 \times 10^{11} \times 7 \times 10^{-3}}$$

$$n = \frac{994.89 \times 10^6 \times (500 \times 10^{-3})^2}{10 \times 10^{-3} \times 4 \times 2 \times 10^{11} \times 7 \times 10^{-3}}$$

$$n = \frac{248.72 \times 10^6}{560 \times 10^5}$$

$$n = 4.44 \cong 5 \text{ coils}$$

UNIT-IV

DEFLECTION OF BEAMS

Deflection of Beams

Introduction:

In all practical engineering applications, when we use the different components, normally we have to operate them within the certain limits i.e. the constraints are placed on the performance and behavior of the components. For instance we say that the particular component is supposed to operate within this value of stress and the deflection of the component should not exceed beyond a particular value.

In some problems the maximum stress however, may not be a strict or severe condition but there may be the deflection which is the more rigid condition under operation. It is obvious therefore to study the methods by which we can predict the deflection of members under lateral loads or transverse loads, since it is this form of loading which will generally produce the greatest deflection of beams.

Assumption: The following assumptions are undertaken in order to derive a differential equation of elastic curve for the loaded beam

1. Stress is proportional to strain i.e. hooks law applies. Thus, the equation is valid only for beams that are not stressed beyond the elastic limit.
2. The curvature is always small.
3. Any deflection resulting from the shear deformation of the material or shear stresses is neglected.

It can be shown that the deflections due to shear deformations are usually small and hence can be ignored.

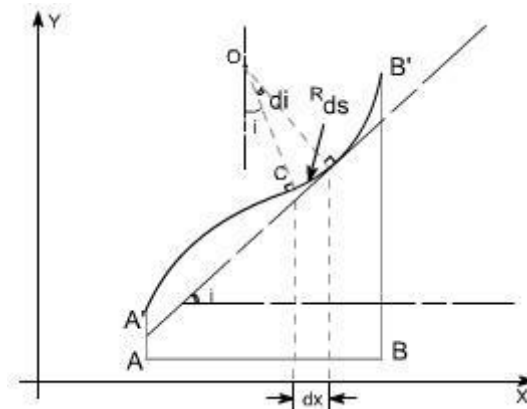

Consider a beam AB which is initially straight and horizontal when unloaded. If under the action of loads the beam deflects to a position A'B' under load or in fact we say that the axis of the beam bends to a shape A'B'. It is customary to call A'B' the curved axis of the beam as the elastic line or deflection curve.

In the case of a beam bent by transverse loads acting in a plane of symmetry, the bending moment M varies along the length of the beam and we represent the variation of bending moment in B.M diagram. Further, it is assumed that the simple bending theory equation holds good.

$$\frac{\sigma}{y} = \frac{M}{I} = \frac{E}{R}$$

If we look at the elastic line or the deflection curve, this is obvious that the curvature at every point is different; hence the slope is different at different points.

To express the deflected shape of the beam in rectangular co-ordinates let us take two axes x and y, x-axis coincide with the original straight axis of the beam and the y – axis shows the deflection.

Further, let us consider an element ds of the deflected beam. At the ends of this element let us construct the normal which intersect at point O denoting the angle between these two normal be di

But for the deflected shape of the beam the slope i at any point C is defined,

$$\tan i = \frac{dy}{dx} \quad \dots\dots(1) \quad \text{or} \quad i = \frac{dy}{dx} \quad \text{Assuming } \tan i = i$$

Further

$$ds = R di$$

however,

$$ds = dx \quad [\text{usually for small curvature}]$$

Hence

$$ds = dx = R di$$

$$\text{or} \quad \frac{di}{dx} = \frac{1}{R}$$

substituting the value of i, one get

$$\frac{d}{dx} \left(\frac{dy}{dx} \right) = \frac{1}{R} \quad \text{or} \quad \frac{d^2 y}{dx^2} = \frac{1}{R}$$

From the simple bending theory

$$\frac{M}{I} = \frac{E}{R} \quad \text{or} \quad M = \frac{EI}{R}$$

so the basic differential equation governing the deflection of beams is

$$M = EI \frac{d^2 y}{dx^2}$$

This is the differential equation of the elastic line for a beam subjected to bending in the plane of symmetry. Its solution $y = f(x)$ defines the shape of the elastic line or the deflection curve as it is frequently called.

Relationship between shear force, bending moment and deflection: The relationship among shear force, bending moment and deflection of the beam may be obtained as

Differentiating the equation as derived

$$\frac{dM}{dx} = EI \frac{d^3 y}{dx^3} \quad \text{Recalling } \frac{dM}{dx} = F$$

Thus,

$$F = EI \frac{d^3 y}{dx^3}$$

Therefore, the above expression represents the shear force whereas rate of intensity of loading can also be found out by differentiating the expression for shear force

$$\text{i.e } w = -\frac{dF}{dx}$$

$$w = -EI \frac{d^4 y}{dx^4}$$

Therefore if 'y' is the deflection of the loaded beam, then the following important relations can be arrived at

$$\text{slope} = \frac{dy}{dx}$$

$$\text{B.M} = EI \frac{d^2 y}{dx^2}$$

$$\text{Shear force} = EI \frac{d^3 y}{dx^3}$$

$$\text{load distribution} = EI \frac{d^4 y}{dx^4}$$

Methods for finding the deflection: The deflection of the loaded beam can be obtained various methods. The one of the method for finding the deflection of the beam is the direct integration method, i.e. the method using the differential equation which we have derived.

Direct integration method: The governing differential equation is defined as

$$M = EI \frac{d^2 y}{dx^2} \quad \text{or} \quad \frac{M}{EI} = \frac{d^2 y}{dx^2}$$

on integrating one get,

$$\frac{dy}{dx} = \int \frac{M}{EI} dx + A \text{ ---- this equation gives the slope}$$

of the loaded beam.

Integrate once again to get the deflection.

$$y = \iint \frac{M}{EI} dx + Ax + B$$

Where A and B are constants of integration to be evaluated from the known conditions of slope and deflections for the particular value of x.

Illustrative examples : let us consider few illustrative examples to have a familiarity with the direct integration method

Case 1: Cantilever Beam with Concentrated Load at the end:- A cantilever beam is subjected to a concentrated load W at the free end, it is required to determine the deflection of the beam

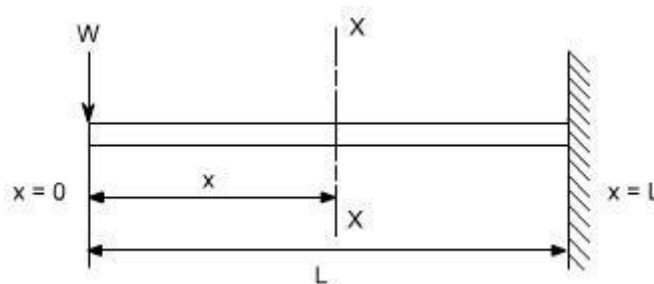

In order to solve this problem, consider any X-section X-X located at a distance x from the left end or the reference, and write down the expressions for the shear force and the bending moment

$$S.F|_{x-x} = -W$$

$$B.M|_{x-x} = -W.x$$

$$\text{Therefore } M|_{x-x} = -W.x$$

$$\text{the governing equation } \frac{M}{EI} = \frac{d^2 y}{dx^2}$$

substituting the value of M in terms of x then integrating the equation one get

$$\frac{M}{EI} = \frac{d^2 y}{dx^2}$$

$$\frac{d^2 y}{dx^2} = -\frac{Wx}{EI}$$

$$\int \frac{d^2 y}{dx^2} = \int -\frac{Wx}{EI} dx$$

$$\frac{dy}{dx} = -\frac{Wx^2}{2EI} + A$$

Integrating once more,

$$\int \frac{dy}{dx} = \int -\frac{Wx^2}{2EI} dx + \int A dx$$

$$y = -\frac{Wx^3}{6EI} + Ax + B$$

The constants A and B are required to be found out by utilizing the boundary conditions as defined below

$$\text{i.e at } x=L ; y=0 \text{-----(1)}$$

$$\text{at } x=L ; dy/dx = 0 \text{-----(2)}$$

Utilizing the second condition, the value of constant A is obtained as

$$A = \frac{WF^2}{2EI}$$

While employing the first condition yields

$$y = -\frac{WL^3}{6EI} + AL + B$$

$$B = \frac{WL^3}{6EI} - AL$$

$$= \frac{WL^3}{6EI} - \frac{WL^3}{2EI}$$

$$= \frac{WL^3 - 3WL^3}{6EI} = -\frac{2WL^3}{6EI}$$

$$B = -\frac{WL^3}{3EI}$$

Substituting the values of A and B we get

$$y = \frac{1}{EI} \left[-\frac{Wx^3}{6EI} + \frac{WL^2 x}{2EI} - \frac{WL^3}{3EI} \right]$$

The slope as well as the deflection would be maximum at the free end hence putting $x=0$ we get,

$$y_{\max} = -\frac{WL^3}{3EI}$$

$$(\text{Slope})_{\max} = +\frac{WL^2}{2EI}$$

Case 2: A Cantilever with Uniformly distributed Loads:- In this case the cantilever beam is subjected to U.D.L with rate of intensity varying w / length. The same procedure can also be adopted in this case

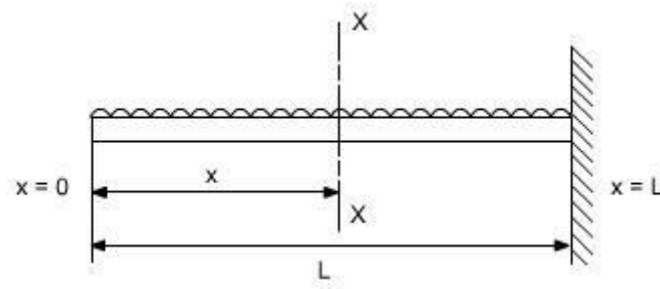

$$\text{S.F}|_{x-x} = -w$$

$$\text{BM}|_{x-x} = -w \cdot x \cdot \frac{x}{2} = w \left(\frac{x^2}{2} \right)$$

$$\frac{M}{EI} = \frac{d^2 y}{dx^2}$$

$$\frac{d^2 y}{dx^2} = -\frac{wx^2}{2EI}$$

$$\int \frac{d^2 y}{dx^2} = \int -\frac{wx^2}{2EI} dx$$

$$\frac{dy}{dx} = -\frac{wx^3}{6EI} + A$$

$$\int \frac{dy}{dx} = \int -\frac{wx^3}{6EI} dx + \int A dx$$

$$y = -\frac{wx^4}{24EI} + Ax + B$$

Boundary conditions relevant to the problem are as follows:

1. At $x = L$; $y = 0$
2. At $x = L$; $dy/dx = 0$

The second boundary conditions yields

$$A = +\frac{wx^3}{6EI}$$

whereas the first boundary conditions yields

$$B = \frac{wL^4}{24EI} - \frac{wL^4}{6EI}$$

$$B = -\frac{wL^4}{8EI}$$

$$\text{Thus, } y = \frac{1}{EI} \left[-\frac{wx^4}{24} + \frac{wL^3 x}{6} - \frac{wL^4}{8} \right]$$

So y_{max} will be at $x = 0$

$$y_{\text{max}} = -\frac{wL^4}{8EI}$$

$$\left(\frac{dy}{dx} \right)_{\text{max}} = \frac{wL^3}{6EI}$$

Case 3: Simply Supported beam with uniformly distributed Loads:- In this case a simply supported beam is subjected to a uniformly distributed load whose rate of intensity varies as w / length.

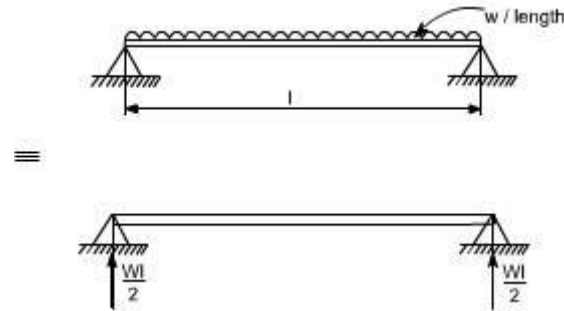

In order to write down the expression for bending moment consider any cross-section at distance of x metre from left end support.

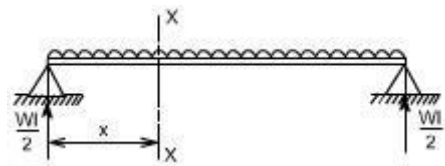

$$S.F|_{x-x} = w \left(\frac{l}{2} \right) - w \cdot x$$

$$B.M|_{x-x} = w \cdot \left(\frac{l}{2} \right) \cdot x - w \cdot x \cdot \left(\frac{x}{2} \right)$$

$$= \frac{wl \cdot x}{2} - \frac{wx^2}{2}$$

The differential equation which gives the elastic curve for the deflected beam is

$$\frac{d^2 y}{dx^2} = \frac{M}{EI} = \frac{1}{EI} \left[\frac{wl \cdot x}{2} - \frac{wx^2}{2} \right]$$

$$\frac{dy}{dx} = \int \frac{wlx}{2EI} dx - \int \frac{wx^2}{2EI} dx + A$$

$$= \frac{wlx^2}{4EI} - \frac{wx^3}{6EI} + A$$

Integrating, once more one gets

$$y = \frac{wlx^3}{12EI} - \frac{wx^4}{24EI} + A \cdot x + B \quad \text{----- (1)}$$

Boundary conditions which are relevant in this case are that the deflection at each support must be zero.

i.e. at $x = 0$; $y = 0$: at $x = l$; $y = 0$

let us apply these two boundary conditions on equation (1) because the boundary conditions are on y , This yields $B = 0$.

$$0 = \frac{wl^4}{12EI} - \frac{wl^4}{24EI} + A.l$$

$$A = -\frac{wl^3}{24EI}$$

So the equation which gives the deflection curve is

$$y = \frac{1}{EI} \left[\frac{wLx^3}{12} - \frac{wx^4}{24} - \frac{wL^3x}{24} \right]$$

Further

In this case the maximum deflection will occur at the centre of the beam where $x = L/2$ [i.e. at the position where the load is being applied]. So if we substitute the value of $x = L/2$

$$\text{Then } y_{\max} = \frac{1}{EI} \left[\frac{wL}{12} \left(\frac{L^3}{8} \right) - \frac{w}{24} \left(\frac{L^4}{16} \right) - \frac{wL^3}{24} \left(\frac{L}{2} \right) \right]$$

$$y_{\max} = -\frac{5wL^4}{384EI}$$

Conclusions

- (i) The value of the slope at the position where the deflection is maximum would be zero.
- (ii) The value of maximum deflection would be at the centre i.e. at $x = L/2$.

The final equation which governs the deflection of the loaded beam in this case is

$$y = \frac{1}{EI} \left[\frac{wLx^3}{12} - \frac{wx^4}{24} - \frac{wL^3x}{24} \right]$$

By successive differentiation one can find the relations for slope, bending moment, shear force and rate of loading.

Deflection (y)

$$yEI = \left[\frac{wLx^3}{12} - \frac{wx^4}{24} - \frac{wL^3x}{24} \right]$$

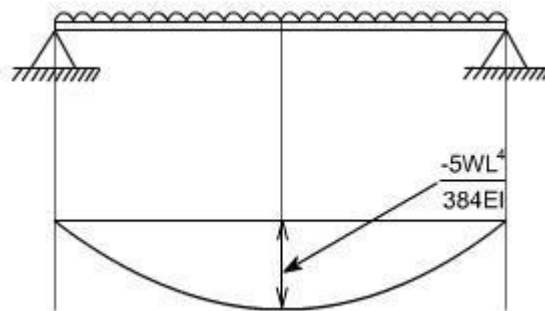

Slope (dy/dx)

$$EI \frac{dy}{dx} = \left[\frac{3wLx^2}{12} - \frac{4wx^3}{24} - \frac{wL^3}{24} \right]$$

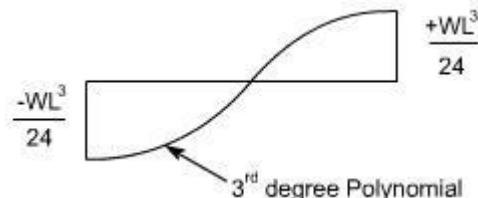

Bending Moment

$$\frac{d^2y}{dx^2} = \frac{1}{EI} \left[\frac{wLx}{2} - \frac{wx^2}{2} \right]$$

So the bending moment diagram would be

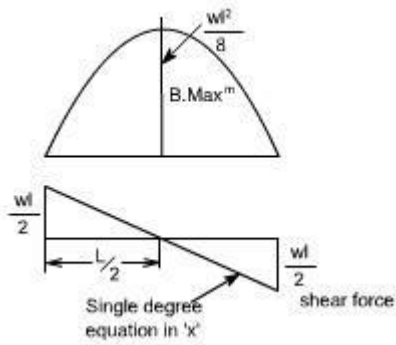

Shear Force

Shear force is obtained by taking

third derivative.

$$EI \frac{d^3 y}{dx^3} = \frac{wL}{2} - w \cdot x$$

Rate of intensity of loading

$$EI \frac{d^4 y}{dx^4} = -w$$

Case 4: The direct integration method may become more involved if the expression for entire beam is not valid for the entire beam. Let us consider a deflection of a simply supported beam which is subjected to a concentrated load W acting at a distance 'a' from the left end.

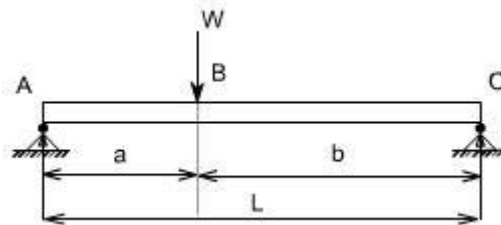

Let R_1 & R_2 be the reactions then,

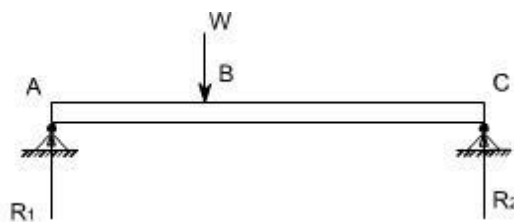

B.M for the portion AB

$$M|_{AB} = R_1 \cdot x \quad 0 \leq x \leq a$$

B.M for the portion BC

$$M|_{BC} = R_1 \cdot x - W(x - a) \quad a \leq x \leq l$$

so the differential equation for the two cases would be,

$$EI \frac{d^2 y}{dx^2} = R_1 \cdot x$$

$$EI \frac{d^2 y}{dx^2} = R_1 \cdot x - W(x - a)$$

These two equations can be integrated in the usual way to find 'y' but this will result in four constants of integration two for each equation. To evaluate the four constants of integration, four independent boundary conditions will be needed since the deflection of each support must be zero, hence the boundary conditions (a) and (b) can be realized.

Further, since the deflection curve is smooth, the deflection equations for the same slope and deflection at the point of application of load i.e. at $x = a$. Therefore four conditions required to evaluate these constants may be defined as follows:

(a) at $x = 0$; $y = 0$ in the portion AB i.e. $0 \leq x \leq a$

(b) at $x = l$; $y = 0$ in the portion BC i.e. $a \leq x \leq l$

(c) at $x = a$; dy/dx , the slope is same for both portion

(d) at $x = a$; y , the deflection is same for both portion

By symmetry, the reaction R_1 is obtained as

$$R_1 = \frac{Wb}{a+b}$$

Hence,

$$EI \frac{d^2 y}{dx^2} = \frac{Wb}{(a+b)} x \quad 0 \leq x \leq a \text{ -----(1)}$$

$$EI \frac{d^2 y}{dx^2} = \frac{Wb}{(a+b)} x - W(x - a) \quad a \leq x \leq l \text{ -----(2)}$$

integrating (1) and (2) we get,

$$EI \frac{dy}{dx} = \frac{Wb}{2(a+b)} x^2 + k_1 \quad 0 \leq x \leq a \text{ -----(3)}$$

$$EI \frac{dy}{dx} = \frac{Wb}{2(a+b)} x^2 - \frac{W(x - a)^2}{2} + k_2 \quad a \leq x \leq l \text{ -----(4)}$$

Using condition (c) in equation (3) and (4) shows that these constants should be equal, hence letting

$$K_1 = K_2 = K$$

Hence

$$EI \frac{dy}{dx} = \frac{Wb}{2(a+b)} x^2 + k \quad 0 \leq x \leq a \text{-----(3)}$$

$$EI \frac{dy}{dx} = \frac{Wb}{2(a+b)} x^2 - \frac{W(x-a)^2}{2} + k \quad a \leq x \leq l \text{----- (4)}$$

Integrating again equation (3) and (4) we get

$$EI y = \frac{Wb}{6(a+b)} x^3 + kx + k_3 \quad 0 \leq x \leq a \text{-----(5)}$$

$$EI y = \frac{Wb}{6(a+b)} x^3 - \frac{W(x-a)^3}{6} + kx + k_4 \quad a \leq x \leq l \text{-----(6)}$$

Utilizing condition (a) in equation (5) yields

$$k_3 = 0$$

Utilizing condition (b) in equation (6) yields

$$0 = \frac{Wb}{6(a+b)} l^3 - \frac{W(l-a)^3}{6} + kl + k_4$$

$$k_4 = -\frac{Wb}{6(a+b)} l^3 + \frac{W(l-a)^3}{6} - kl$$

But $a+b=l$,

Thus,

$$k_4 = -\frac{Wb(a+b)^2}{6} + \frac{Wb^3}{6} - k(a+b)$$

Now lastly k_3 is found out using condition (d) in equation (5) and equation (6), the condition (d) is that,

At $x = a$; y ; the deflection is the same for both portion

Therefore $y|_{\text{from equation 5}} = y|_{\text{from equation 6}}$
or

$$\frac{Wb}{6(a+b)} x^3 + kx + k_3 = \frac{Wb}{6(a+b)} x^3 - \frac{W(x-a)^3}{6} + kx + k_4$$

$$\frac{Wb}{6(a+b)} a^3 + ka + k_3 = \frac{Wb}{6(a+b)} a^3 - \frac{W(a-a)^3}{6} + ka + k_4$$

Thus, $k_4 = 0$;

OR

$$k_4 = -\frac{Wb(a+b)^2}{6} + \frac{Wb^3}{6} - k(a+b) = 0$$

$$k(a+b) = -\frac{Wb(a+b)^2}{6} + \frac{Wb^3}{6}$$

$$k = -\frac{Wb(a+b)}{6} + \frac{Wb^3}{6(a+b)}$$

so the deflection equations for each portion of the beam are

$$EIy = \frac{Wb}{6(a+b)} x^3 + kx + k_3$$

$$EIy = \frac{Wbx^3}{6(a+b)} - \frac{Wb(a+b)x}{6} + \frac{Wb^3x}{6(a+b)} \quad \text{-----for } 0 \leq x \leq a \text{ ----- (7)}$$

and for other portion

$$EIy = \frac{Wb}{6(a+b)} x^3 - \frac{W(x-a)^3}{6} + kx + k_4$$

Substituting the value of 'k' in the above equation

$$EIy = \frac{Wbx^3}{6(a+b)} - \frac{W(x-a)^3}{6} - \frac{Wb(a+b)x}{6} + \frac{Wb^3x}{6(a+b)} \quad \text{For for } a \leq x \leq l \text{ ----- (8)}$$

so either of the equation (7) or (8) may be used to find the deflection at $x = a$

hence substituting $x = a$ in either of the equation we get

$$Y|_{x=a} = -\frac{Wa^2b^2}{3EI(a+b)}$$

OR if $a = b = l/2$

$$Y_{\max} = -\frac{WL^3}{48EI}$$

ALTERNATE METHOD: There is also an alternative way to attempt this problem in a more simpler way. Let us considering the origin at the point of application of the load,

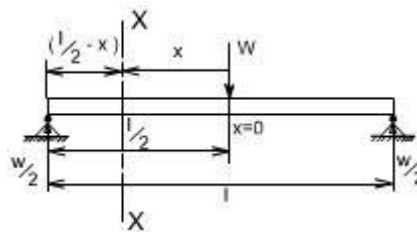

$$S.F|_{xx} = \frac{W}{2}$$

$$B.M|_{xx} = \frac{W}{2} \left(\frac{l}{2} - x \right)$$

substituting the value of M in the governing equation for the deflection

$$\frac{d^2y}{dx^2} = \frac{W}{2} \left(\frac{l}{2} - x \right)$$

$$\frac{dy}{dx} = \frac{1}{EI} \left[\frac{WLx}{4} - \frac{Wx^2}{4} \right] + A$$

$$y = \frac{1}{EI} \left[\frac{WLx^2}{8} - \frac{Wx^3}{12} \right] + A_x + B$$

Boundary conditions relevant for this case are as follows

(i) at $x = 0$; $dy/dx = 0$

hence, $A = 0$

(ii) at $x = l/2$; $y = 0$ (because now $l/2$ is on the left end or right end support since we have taken the origin at the centre)

Thus,

$$0 = \left[\frac{WL^3}{32} - \frac{WL^3}{96} + B \right]$$

$$B = -\frac{WL^3}{48}$$

Hence the equation which governs the deflection would be

$$y = \frac{1}{EI} \left[\frac{WLx^2}{8} - \frac{Wx^3}{12} - \frac{WL^3}{48} \right]$$

Hence

$Y_{\max}^m \Big _{\text{at } x=0} = -\frac{WL^3}{48EI} \quad \text{At the centre}$
$\left(\frac{dy}{dx} \right)_{\max}^m \Big _{\text{at } x=\pm \frac{L}{2}} = \pm \frac{WL^2}{16EI} \quad \text{At the ends}$

Hence the integration method may be bit cumbersome in some of the case. Another limitation of the method would be that if the beam is of non uniform cross section,

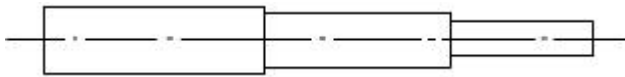

i.e. it is having different cross-section then this method also fails.

So there are other methods by which we find the deflection like

1. Macaulay's method in which we can write the different equation for bending moment for different sections.
2. Area moment methods
3. Energy principle methods

THE AREA-MOMENT / MOMENT-AREA METHODS:

The area moment method is a semi graphical method of dealing with problems of deflection of beams subjected to bending. The method is based on a geometrical interpretation of definite integrals. This is applied to cases where the equation for bending moment to be written is cumbersome and the loading is relatively simple.

Let us recall the figure, which we referred while deriving the differential equation governing the beams.

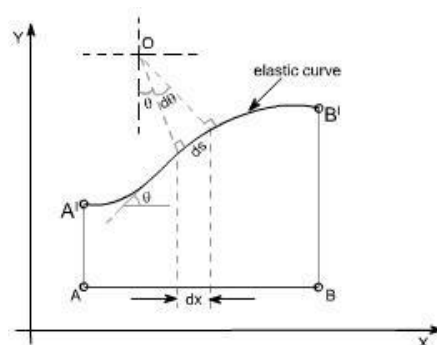

It may be noted that dx is an angle subtended by an arc element ds and M is the bending moment to which this element is subjected.

We can assume,

$$ds = dx \text{ [since the curvature is small]}$$

$$\text{hence, } R d\theta = ds$$

$$\frac{d\theta}{ds} = \frac{1}{R} = \frac{M}{EI}$$

$$\frac{d\theta}{ds} = \frac{M}{EI}$$

But for small curvature [but θ is the angle, slope is $\tan\theta = \frac{dy}{dx}$ for small

angles $\tan\theta \approx \theta$, hence $\theta \approx \frac{dy}{dx}$ so we get $\frac{d^2y}{dx^2} = \frac{M}{EI}$ by putting $ds \approx dx$]

Hence,

$$\frac{d\theta}{dx} = \frac{M}{EI} \text{ or } \boxed{d\theta = \frac{M \cdot dx}{EI}} \text{ ----- (1)}$$

The relationship as described in equation (1) can be given a very simple graphical interpretation with reference to the elastic plane of the beam and its bending moment diagram

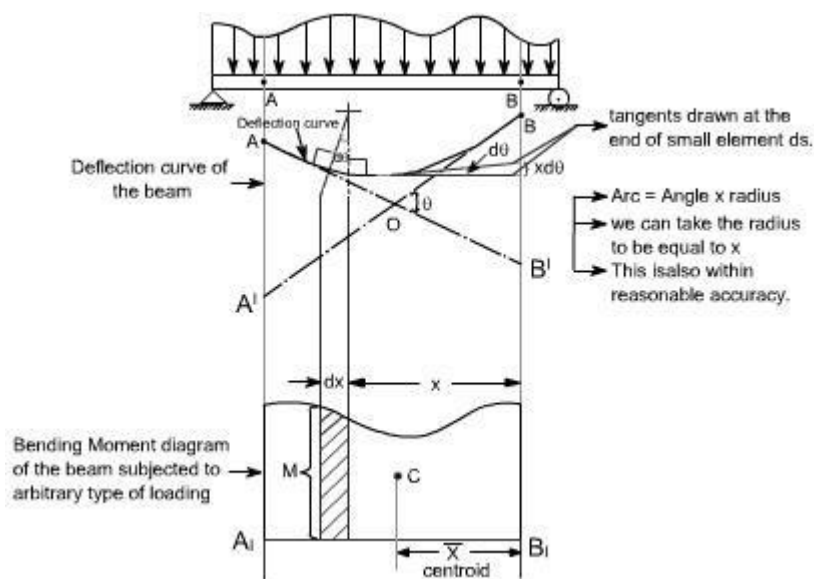

Refer to the figure shown above consider AB to be any portion of the elastic line of the loaded beam and A_1B_1 is its corresponding bending moment diagram.

Let AO = Tangent drawn at A

BO = Tangent drawn at B

Tangents at A and B intersect at the point O.

Further, AA' is the deflection of A away from the tangent at B while the vertical distance $B'B$ is the deflection of point B away from the tangent at A. All these quantities are further understood to be very small.

Let $ds \approx dx$ be any element of the elastic line at a distance x from B and an angle between its tangents be $d\theta$. Then, as derived earlier

$$d\theta = \frac{M \cdot dx}{EI}$$

This relationship may be interpreted as that this angle is nothing but the area $M \cdot dx$ of the shaded bending moment diagram divided by EI .

From the above relationship the total angle θ between the tangents A and B may be determined as

$$\theta = \int_A^B \frac{M dx}{EI} = \frac{1}{EI} \int_A^B M dx$$

Since this integral represents the total area of the bending moment diagram, hence we may conclude this result in the following theorem

Theorem I:

$$\left\{ \begin{array}{l} \text{slope or } \theta \\ \text{between any two points} \end{array} \right\} = \left\{ \begin{array}{l} \frac{1}{EI} \times \text{area of B.M diagram between} \\ \text{corresponding portion of B.M diagram} \end{array} \right\}$$

Now let us consider the deflection of point B relative to tangent at A, this is nothing but the vertical distance BB' . It may be noted from the bending diagram that bending of the element ds contributes to this deflection by an amount equal to $x d\theta$ [each of this intercept may be considered as the arc of a circle of radius x subtended by the angle $d\theta$]

$$\delta = \int_A^B x d\theta$$

Hence the total distance $B'B$ becomes

The limits from A to B have been taken because A and B are the two points on the elastic curve, under consideration]. Let us substitute the value of $d\theta = M dx / EI$ as derived earlier

$$\delta = \int_A^B x \frac{M dx}{EI} = \int_A^B \frac{M dx}{EI} \cdot x \quad \text{[This is in fact the moment of area of the bending moment diagram]}$$

Since $M dx$ is the area of the shaded strip of the bending moment diagram and x is its distance from B, we therefore conclude that right hand side of the above equation represents first moment area with respect to B of the total bending moment area between A and B divided by EI .

Therefore, we are in a position to state the above conclusion in the form of theorem as follows:

Theorem II:

$$\text{Deflection of point 'B' relative to point A} = \frac{1}{EI} \times \left\{ \begin{array}{l} \text{first moment of area with respect} \\ \text{to point B, of the total B.M diagram} \end{array} \right\}$$

Further, the first moment of area, according to the definition of centroid may be written as $A \bar{x}$, where \bar{x} is equal to distance of centroid and A is the total area of bending moment

Thus, $\delta_A = \frac{1}{EI} A \bar{x}$

Therefore, the first moment of area may be obtained simply as a product of the total area of the B.M diagram between the points A and B multiplied by the distance \bar{x} to its centroid C.

If there exists an inflection point or point of contraflexure for the elastic line of the loaded beam between the points A and B, as shown below,

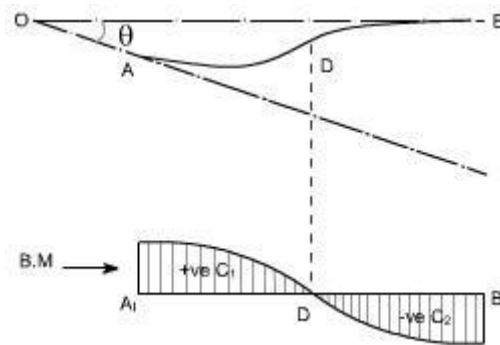

Then, adequate precaution must be exercised in using the above theorem. In such a case B. M diagram gets divide into two portions +ve and -ve portions with centroids C_1 and C_2 . Then to find an angle θ between the tangent sat the points A and B

$$\theta = \int_A^D \frac{M dx}{EI} - \int_D^B \frac{M dx}{EI}$$

And similarly for the deflection of B away from the tangent at A becomes

$$\delta = \int_A^D \frac{M dx}{EI} \cdot x - \int_D^B \frac{M dx}{EI} \cdot x$$

Illustrative Examples: Let us study few illustrative examples, pertaining to the use of these theorems

Example 1:

1. A cantilever is subjected to a concentrated load at the free end. It is required to find out the deflection at the free end.

Fpr a cantilever beam, the bending moment diagram may be drawn as shown below

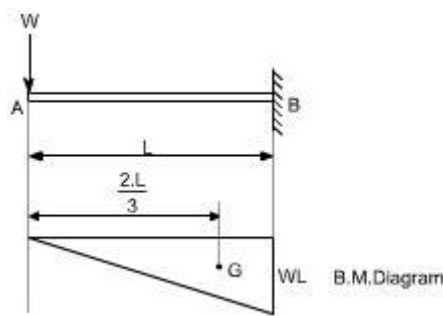

Let us work out this problem from the zero slope condition and apply the first area - moment theorem

$$\begin{aligned} \text{slope at A} &= \frac{1}{EI} [\text{Area of B.M diagram between the points A and B}] \\ &= \frac{1}{EI} \left[\frac{1}{2} L \cdot WL \right] \\ &= \frac{WL^2}{2EI} \end{aligned}$$

The deflection at A (relative to B) may be obtained by applying the second area - moment theorem

NOTE: In this case the point B is at zero slope.

Thus,

$$\begin{aligned} \delta &= \frac{1}{EI} [\text{first moment of area of B.M diagram between A and B about A}] \\ &= \frac{1}{EI} [A\bar{y}] \\ &= \frac{1}{EI} \left[\left(\frac{1}{2} L \cdot WL \right) \frac{2}{3} L \right] \\ &= \frac{WL^3}{3EI} \end{aligned}$$

Example 2: Simply supported beam is subjected to a concentrated load at the mid span determine the value of deflection.

A simply supported beam is subjected to a concentrated load W at point C. The bending moment diagram is drawn below the loaded beam.

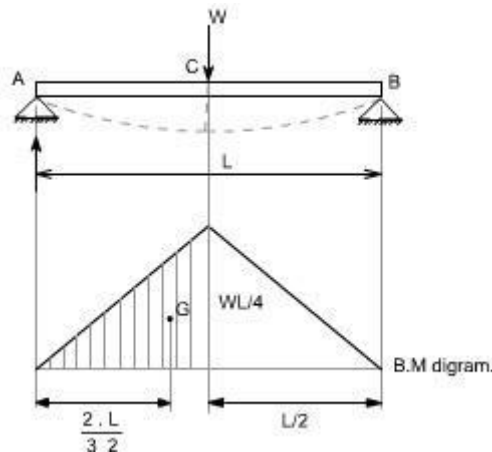

Again working relative to the zero slope at the centre C.

$$\begin{aligned} \text{slope at A} &= \frac{1}{EI} [\text{Area of B.M diagram between A and C}] \\ &= \frac{1}{EI} \left[\left(\frac{1}{2} \right) \left(\frac{L}{2} \right) \left(\frac{WL}{4} \right) \right] \text{ we are taking half area of the B.M because we} \\ &\hspace{10em} \text{have to work out this relative to a zero slope} \\ &= \frac{WL^2}{16EI} \end{aligned}$$

Deflection of A relative to C = central deflection of C

or

$$\begin{aligned} \delta_c &= \frac{1}{EI} [\text{Moment of B.M diagram between points A and C about A}] \\ &= \frac{1}{EI} \left[\left(\frac{1}{2} \right) \left(\frac{L}{2} \right) \left(\frac{WL}{4} \right) \frac{2}{3} L \right] \\ &= \frac{WL^3}{48EI} \end{aligned}$$

Example 3: A simply supported beam is subjected to a uniformly distributed load, with a intensity of loading W / length . It is required to determine the deflection.

The bending moment diagram is drawn, below the loaded beam, the value of maximum B.M is equal to $WL^2 / 8$

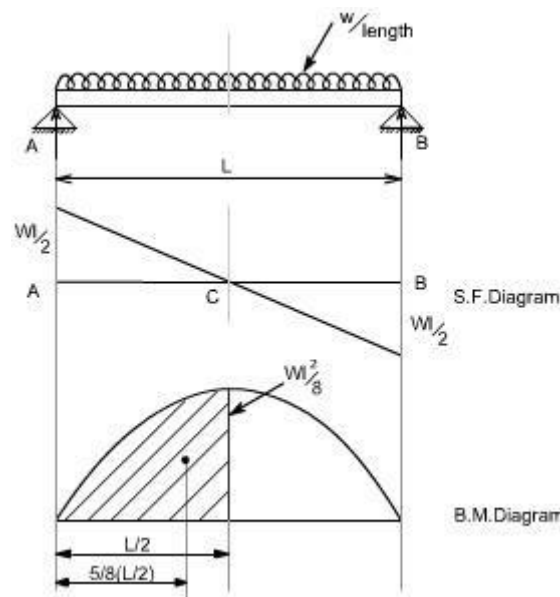

So by area moment method,

$$\begin{aligned} \text{Slope at point C w.r.t point A} &= \frac{1}{EI} [\text{Area of B.M diagram between point A and C}] \\ &= \frac{1}{EI} \left[\left(\frac{2}{3} \right) \left(\frac{WL^2}{8} \right) \left(\frac{L}{2} \right) \right] \\ &= \frac{WL^3}{24EI} \end{aligned}$$

$$\text{Deflection at point C} = \frac{1}{EI} [A \bar{y}]$$

relative to A

$$\begin{aligned} &= \frac{1}{EI} \left[\left(\frac{WL^3}{24} \right) \left(\frac{5}{8} \right) \left(\frac{L}{2} \right) \right] \\ &= \frac{5}{384EI} .WL^4 \end{aligned}$$

Macaulay's Methods

If the loading conditions change along the span of beam, there is corresponding change in moment equation. This requires that a separate moment equation be written between each change of load point and that two integration be made for each such moment equation. Evaluation of the constants introduced by each integration can become very involved.

Fortunately, these complications can be avoided by writing single moment equation in such a way that it becomes continuous for entire length of the beam in spite of the discontinuity of loading.

Note : In Macaulay's method some author's take the help of unit function approximation (i.e. Laplace transform) in order to illustrate this method, however both are essentially the same.

For example consider the beam shown in fig below:

Let us write the general moment equation using the definition $M = (\sum M)_L$, Which means that we consider the effects of loads lying on the left of an exploratory section. The moment equations for the portions AB,BC and CD are written as follows

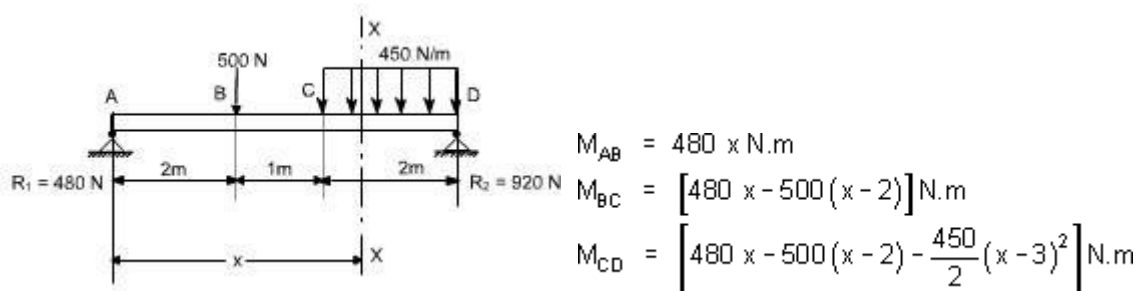

It may be observed that the equation for M_{CD} will also be valid for both M_{AB} and M_{BC} provided that the terms $(x-2)$ and $(x-3)^2$ are neglected for values of x less than 2 m and 3 m, respectively. In other words, the terms $(x-2)$ and $(x-3)^2$ are nonexistent for values of x for which the terms in parentheses are negative.

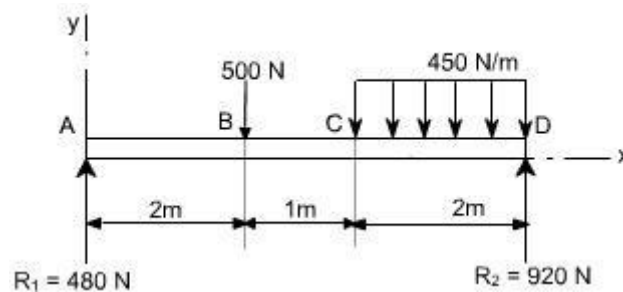

As an clear indication of these restrictions, one may use a nomenclature in which the usual form of parentheses is replaced by pointed brackets, namely, $\langle \rangle$. With this changein nomenclature, we obtain a single moment equation

$$M = \left(480x - 500 \langle x-2 \rangle - \frac{450}{2} \langle x-3 \rangle^2 \right) N.m$$

Which is valid for the entire beam if we postulate that the terms between the pointed brackets do not exists for negative values; otherwise the term is to be treated like any ordinary expression.

As an another example, consider the beam as shown in the fig below. Here the distributed load extends only over the segment BC. We can create continuity, however, by assuming that the distributed load extends beyond C and adding an equal upward-distributed load to cancel its

effect beyond C, as shown in the adjacent fig below. The general moment equation, written for the last segment DE in the new nomenclature may be written as:

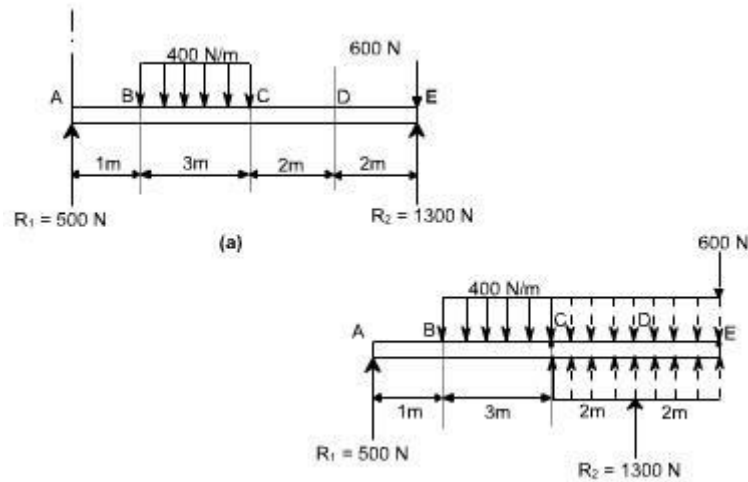

$$M = \left(500x - \frac{400}{2}(x-1)^2 + \frac{400}{2}(x-4)^2 + 1300(x-6) \right) \text{N.m}$$

It may be noted that in this equation effect of load 600 N won't appear since it is just at the last end of the beam so if we assume the exploratory just at section at just the point of application of 600 N than $x = 0$ or else we will here take the X - section beyond 600 N which is invalid.

Procedure to solve the problems

- (i). After writing down the moment equation which is valid for all values of 'x' i.e. containing pointed brackets, integrate the moment equation like an ordinary equation.
- (ii). While applying the B.C's keep in mind the necessary changes to be made regarding the pointed brackets.

Illustrative Examples :

1. A concentrated load of 300 N is applied to the simply supported beam as shown in Fig. Determine the equations of the elastic curve between each change of load point and the maximum deflection in the beam.

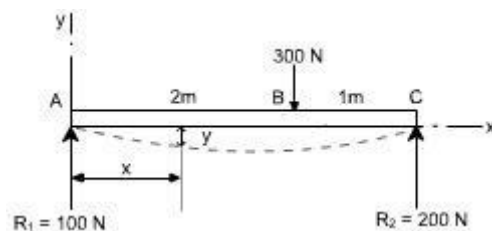

Solution : writing the general moment equation for the last portion BC of the loaded beam,

$$EI \frac{d^2 y}{dx^2} = M = (100x - 300(x - 2)) \text{ N.m} \quad \dots\dots(1)$$

Integrating twice the above equation to obtain slope and the deflection

$$EI \frac{dy}{dx} = (50x^2 - 150(x - 2)^2 + C_1) \text{ N.m}^2 \quad \dots\dots(2)$$

$$EI y = \left(\frac{50}{3} x^3 - 50(x - 2)^3 + C_1 x + C_2 \right) \text{ N.m}^3 \quad \dots\dots(3)$$

To evaluate the two constants of integration. Let us apply the following boundary conditions:

1. At point A where $x = 0$, the value of deflection $y = 0$. Substituting these values in Eq. (3) we find $C_2 = 0$. keep in mind that $\langle x - 2 \rangle^3$ is to be neglected for negative values.

2. At the other support where $x = 3\text{m}$, the value of deflection y is also zero.

substituting these values in the deflection Eq. (3), we obtain

$$0 = \left(\frac{50}{3} 3^3 - 50(3 - 2)^3 + 3.C_1 \right) \text{ or } C_1 = -133 \text{ N.m}^2$$

Having determined the constants of integration, let us make use of Eqs. (2) and (3) to rewrite the slope and deflection equations in the conventional form for the two portions.

segment AB ($0 \leq x \leq 2\text{m}$)

$$EI \frac{dy}{dx} = (50x^2 - 133) \text{ N.m}^2 \quad \dots\dots(4)$$

$$EI y = \left(\frac{50}{3} x^3 - 133x \right) \text{ N.m}^3 \quad \dots\dots(5)$$

segment BC ($2\text{m} \leq x \leq 3\text{m}$)

$$EI \frac{dy}{dx} = (50x^2 - 150(x - 2)^2 - 133x) \text{ N.m}^2 \quad \dots\dots(6)$$

$$EI y = \left(\frac{50}{3} x^3 - 50(x - 2)^3 - 133x \right) \text{ N.m}^3 \quad \dots\dots(7)$$

Continuing the solution, we assume that the maximum deflection will occur in the segment AB. Its location may be found by differentiating Eq. (5) with respect to x and setting the derivative to be equal to zero, or, what amounts to the same thing, setting the slope equation (4) equal to zero and solving for the point of zero slope.

We obtain

$50x^2 - 133 = 0$ or $x = 1.63 \text{ m}$ (It may be kept in mind that if the solution of the equation does not yield a value $< 2 \text{ m}$ then we have to try the other equations which are valid for segment BC)

Since this value of x is valid for segment AB, our assumption that the maximum deflection occurs in this region is correct. Hence, to determine the maximum deflection, we substitute $x = 1.63 \text{ m}$ in Eq (5), which yields

$$EI y |_{\text{max}} = -145 \text{ N.m}^3 \quad \dots\dots(8)$$

The negative value obtained indicates that the deflection y is downward from the x axis. quite usually only the magnitude of the deflection, without regard to sign, is desired; this is denoted by \square , the use of y may be reserved to indicate a directed value of deflection.

if $E = 30 \text{ Gpa}$ and $I = 1.9 \times 10^6 \text{ mm}^4 = 1.9 \times 10^{-6} \text{ m}^4$, Eq. (h) becomes

$$y|_{\text{max}m} = (30 \times 10^9) (1.9 \times 10^{-6})$$

Then $= -2.54 \text{ mm}$

Example 2:

It is required to determine the value of EIy at the position midway between the supports and at the overhanging end for the beam shown in figure below.

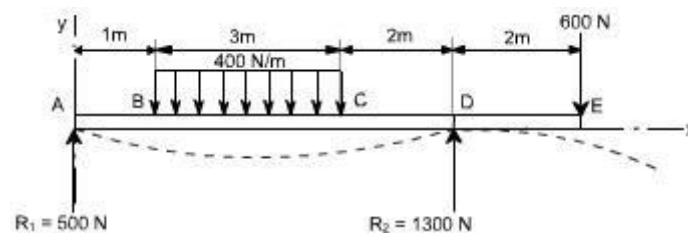

Solution:

Writing down the moment equation which is valid for the entire span of the beam and applying the differential equation of the elastic curve, and integrating it twice, we obtain

$$EI \frac{d^2 y}{dx^2} = M = \left(500x - \frac{400}{2}(x-1)^2 + \frac{400}{2}(x-4)^2 + 1300(x-6) \right) \text{N.m}$$

$$EI \frac{dy}{dx} = \left(250x^2 - \frac{200}{3}(x-1)^3 + \frac{200}{3}(x-4)^3 + 650(x-6)^2 + C_1 \right) \text{N.m}$$

$$EIy = \left(\frac{250}{3}x^3 - \frac{50}{3}(x-1)^4 + \frac{50}{3}(x-4)^4 + \frac{650}{3}(x-6)^3 + C_1x + C_2 \right) \text{N.m}^3$$

To determine the value of C_2 , It may be noted that $EIy = 0$ at $x = 0$, which gives $C_2 = 0$. Note that the negative terms in the pointed brackets are to be ignored Next, let us use the condition that $EIy = 0$ at the right support where $x = 6\text{m}$. This gives

$$0 = \frac{250}{3}(6)^3 - \frac{50}{3}(5)^4 + \frac{50}{3}(2)^4 + 6C_1 \text{ or } C_1 = -1308 \text{N.m}^2$$

Finally, to obtain the midspan deflection, let us substitute the value of $x = 3\text{m}$ in the deflection equation for the segment BC obtained by ignoring negative values of the bracketed terms $\square x - 4 \square^4$ and $\square x - 6 \square^3$. We obtain

$$EIy = \frac{250}{3}(3)^3 - \frac{50}{3}(2)^4 - 1308(3) = -1941 \text{ N.m}^3$$

For the overhanging end where $x=8 \text{ m}$, we have

$$EIy = \left(\frac{250}{3}(8)^3 - \frac{50}{3}(7)^4 + \frac{50}{3}(4)^4 + \frac{650}{3}(2)^3 - 1308(8) \right) = -1814 \text{ N.m}^3$$

Example 3:

A simply supported beam carries the triangularly distributed load as shown in figure. Determine the deflection equation and the value of the maximum deflection.

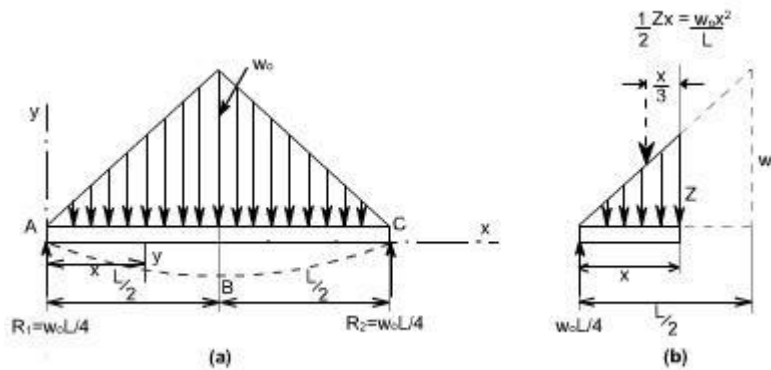

Solution:

Due to symmetry, the reactions is one half the total load of $1/2w_0L$, or $R_1 = R_2 = 1/4w_0L$. Due to the advantage of symmetry to the deflection curve from A to B is the mirror image of that from C to B. The condition of zero deflection at A and of zero slope at B do not require the use of a general moment equation. Only the moment equation for segment AB is needed, and this may be easily written with the aid of figure(b).

Taking into account the differential equation of the elastic curve for the segment AB and integrating twice, one can obtain

$$EI \frac{d^2y}{dx^2} = M_{AB} = \frac{w_0L}{4}x - \frac{w_0x^2}{L} \cdot \frac{x}{3} \quad \dots\dots(1)$$

$$EI \frac{dy}{dx} = \frac{w_0Lx^2}{8} - \frac{w_0x^4}{12L} + C_1 \quad \dots\dots(2)$$

$$EIy = \frac{w_0Lx^3}{24} - \frac{w_0x^5}{60L} + C_1x + C_2 \dots\dots(3)$$

In order to evaluate the constants of integration, let us apply the B.C's we note that at the support A, $y = 0$ at $x = 0$. Hence from equation (3), we get $C_2 = 0$. Also, because of symmetry, the slope $dy/dx = 0$ at midspan where $x = L/2$. Substituting these conditions in equation (2) we get

$$0 = \frac{w_0L}{8} \left(\frac{L}{2}\right)^2 - \frac{w_0}{12L} \left(\frac{L}{2}\right)^4 + C_1 \cdot \frac{L}{2} = -\frac{5w_0L^3}{192}$$

Hence the deflection equation from A to B (and also from C to B because of symmetry) becomes

$$EIy = \frac{w_0Lx^3}{24} - \frac{w_0x^5}{60L} - \frac{5w_0L^3x}{192}$$

Which reduces to

$$EIy = -\frac{w_0x}{960L} (25L^4 - 40L^2x^2 + 16x^4)$$

The maximum deflection at midspan, where $x = L/2$ is then found to be

$$EIy = -\frac{w_0L^4}{120}$$

Example 4: couple acting

Consider a simply supported beam which is subjected to a couple M at a distance 'a' from the left end. It is required to determine using the Macauley's method.

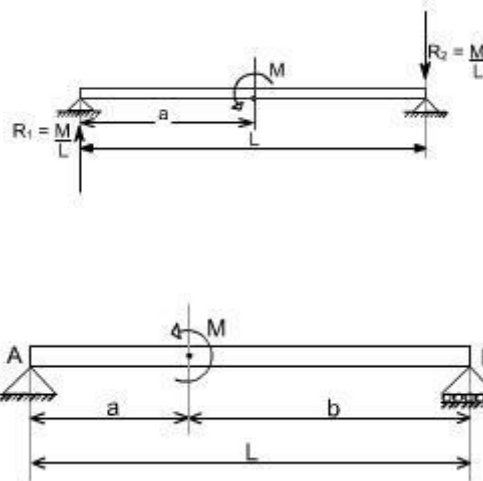

Therefore, writing the general moment equation we get

$$M = R_1 x - M \langle x - a \rangle \text{ or } EI \frac{d^2 y}{dx^2} = M$$

Integrating twice we get

$$EI \frac{dy}{dx} = R_1 \cdot \frac{x^2}{2} - M \langle x - a \rangle^1 + C_1$$

$$EI \cdot y = R_1 \cdot \frac{x^3}{6} - \frac{M}{2} \langle x - a \rangle^2 + C_1 x + C_2$$

Example 5: A simply supported beam is subjected to U.d.l in combination with couple M . It is required to determine the deflection.

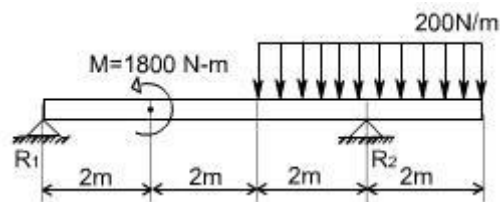

This problem may be attempted in the same way. The general moment equation may be written as

$$\begin{aligned} M(x) &= R_1 x - 1800 \langle x - 2 \rangle^0 - \frac{200 \langle x - 4 \rangle \langle x - 4 \rangle}{2} + R_2 \langle x - 6 \rangle \\ &= R_1 x - 1800 \langle x - 2 \rangle^0 - \frac{200 \langle x - 4 \rangle^2}{2} + R_2 \langle x - 6 \rangle \end{aligned}$$

Thus,

$$EI \frac{d^2 y}{dx^2} = R_1 x - 1800 \langle x - 2 \rangle^0 - \frac{200 \langle x - 4 \rangle^2}{2} + R_2 \langle x - 6 \rangle$$

Integrate twice to get the deflection of the loaded beam.

UNIT-V

THIN CYLINDERS, SPHERES AND THICK CYLINDERS

Members Subjected to Axisymmetric Loads

Pressurized thin walled cylinder:

Preamble : Pressure vessels are exceedingly important in industry. Normally two types of pressure vessel are used in common practice such as cylindrical pressure vessel and spherical pressure vessel.

In the analysis of thin walled cylinders subjected to internal pressures it is assumed that the radial stress remains radial and the wall thickness does not change due to internal pressure. Although the internal pressure acting on the wall causes a local compressive stress (equal to pressure) but its value is negligibly small as compared to other stresses & hence the state of stress of an element of a thin walled cylinder is considered a biaxial one.

Further in the analysis of thin walled cylinders, the weight of the fluid is considered negligible.

Let us consider a long cylinder of circular cross-section with an internal radius of R_2 and a constant wall thickness 't' as shown in fig.

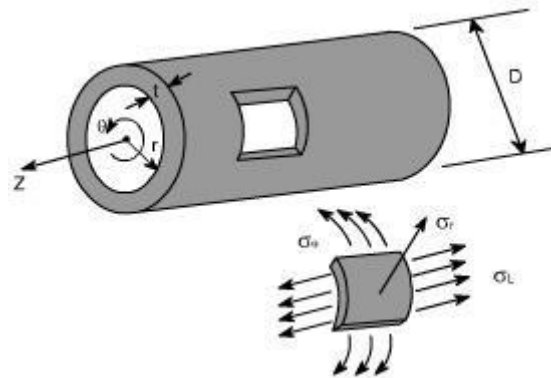

This cylinder is subjected to a difference of hydrostatic pressure of 'p' between its inner and outer surfaces. In many cases, 'p' between gage pressure within the cylinder, taking outside pressure to be ambient.

By thin walled cylinder we mean that the thickness 't' is very much smaller than the radius R_i and we may quantify this by stating that the ratio t / R_i of thickness of radius should be less than 0.1.

An appropriate co-ordinate system to be used to describe such a system is the cylindrical polar one r, θ, z shown, where z axis lies along the axis of the cylinder, r is radial to it and θ is the angular co-ordinate about the axis.

The small piece of the cylinder wall is shown in isolation, and stresses in respective direction have also been shown.

Type of failure:

Such a component fails in service when subjected to an excessively high internal pressure. While it might fail by bursting along a path following the circumference of the cylinder. Under normal circumstances it fails by bursting along a path parallel to the axis. This suggests that the hoop stress is significantly higher than the axial stress.

In order to derive the expressions for various stresses we make following

Applications :

Liquid storage tanks and containers, water pipes, boilers, submarine hulls, and certain air plane components are common examples of thin walled cylinders and spheres, roof domes.

ANALYSIS : In order to analyse the thin walled cylinders, let us make the following assumptions :

- There are no shear stresses acting in the wall.
- The longitudinal and hoop stresses do not vary through the wall.
- Radial stresses σ_r which acts normal to the curved plane of the isolated element are negligibly small as compared to other two stresses especially when $\left[\frac{t}{R_i} < \frac{1}{20} \right]$

The state of stress for an element of a thin walled pressure vessel is considered to be biaxial, although the internal pressure acting normal to the wall causes a local compressive stress equal to the internal pressure, Actually a state of tri-axial stress exists on the inside of the vessel. However, for thin walled pressure vessel the third stress is much smaller than the other two stresses and for this reason it can be neglected.

Thin Cylinders Subjected to Internal Pressure:

When a thin – walled cylinder is subjected to internal pressure, three mutually perpendicular principal stresses will be set up in the cylinder materials, namely

- Circumferential or hoop stress
- The radial stress
- Longitudinal stress

now let us define these stresses and determine the expressions for them

Hoop or circumferential stress:

This is the stress which is set up in resisting the bursting effect of the applied pressure and can be most conveniently treated by considering the equilibrium of the cylinder.

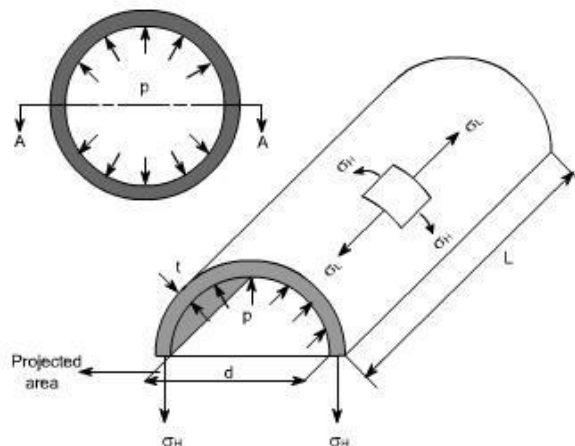

In the figure we have shown a one half of the cylinder. This cylinder is subjected to an internal pressure p .

i.e. p = internal pressure

d = inside diameter

L = Length of the cylinder

t = thickness of the wall

Total force on one half of the cylinder owing to the internal pressure ' p '

$$= p \times \text{Projected Area}$$

$$= p \times d \times L$$

$$= p \cdot d \cdot L \text{ -----(1)}$$

The total resisting force owing to hoop stresses σ_H set up in the cylinder walls

$$= 2 \cdot \sigma_H \cdot L \cdot t \text{ -----(2)}$$

Because $\sigma_H \cdot L \cdot t$ is the force in the one wall of the half cylinder.

the equations (1) & (2) we get

$$2 \cdot \sigma_H \cdot L \cdot t = p \cdot d \cdot L$$

$$\sigma_H = (p \cdot d) / 2t$$

Circumferential or Stress (σ_H) = (p .d)/ 2t	hoop
---	-------------

Longitudinal Stress:

Consider now again the same figure and the vessel could be considered to have closed ends and contains a fluid under a gage pressure p . Then the walls of the cylinder will have a longitudinal stress as well as a circumferential stress.

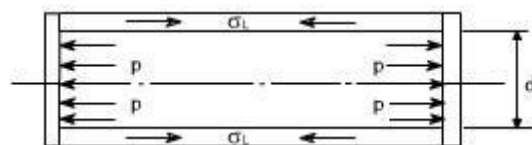

Total force on the end of the cylinder owing to internal pressure

$$= \text{pressure} \times \text{area}$$

$$= p \times \pi d^2 / 4$$

Area of metal resisting this force = $\pi d \cdot t$. (approximately)

because

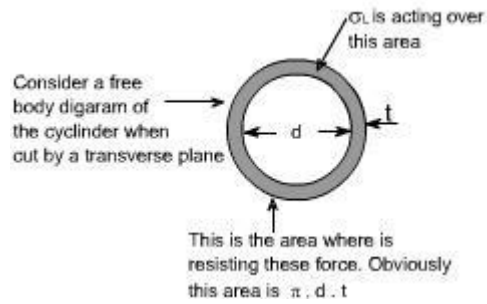

Hence the longitudinal stresses

$$\text{Set up} = \frac{\text{force}}{\text{area}} = \frac{[p \times \pi d^2 / 4]}{\pi d t}$$

$$= \frac{p d}{4 t} \quad \text{or} \quad \sigma_L = \frac{p d}{4 t}$$

or alternatively from equilibrium conditions

$$\sigma_L \cdot (\pi d t) = p \cdot \frac{\pi d^2}{4}$$

Thus $\sigma_L = \frac{p d}{4 t}$

Change in Dimensions :

The change in length of the cylinder may be determined from the longitudinal strain.

Since whenever the cylinder will elongate in axial direction or longitudinal direction, this will also get decreased in diameter or the lateral strain will also take place. Therefore we will have to also take into consideration the lateral strain. as we know that the poisson's ratio (ν) is

$$\nu = \frac{- \text{lateral strain}}{\text{longitudinal strain}}$$

where the -ve sign emphasized that the change is negative

Consider an element of cylinder wall which is subjected to two mutually σ^r normal stresses σ_L and σ_H .

Let E = Young's modulus of elasticity

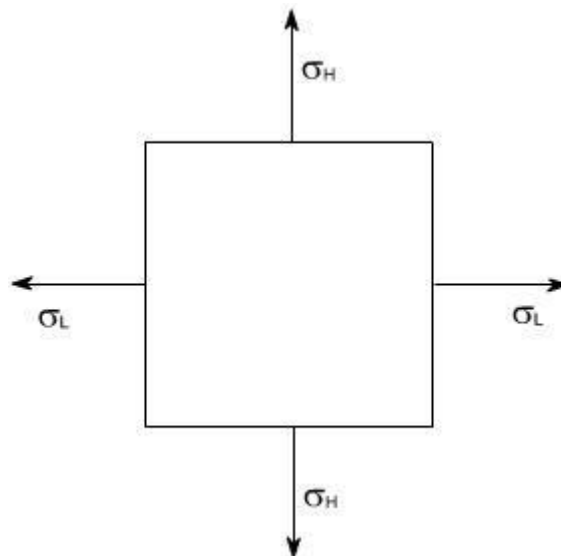

$$\text{Resultant Strain in longitudinal direction} = \frac{\sigma_L}{E} - \nu \frac{\sigma_H}{E} = \frac{1}{E}(\sigma_L - \nu\sigma_H)$$

recalling

$$\sigma_L = \frac{pd}{4t} \quad \sigma_H = \frac{pd}{2t}$$

$$\epsilon_1 \text{ (longitudinal strain)} = \frac{pd}{4Et}[1-2\nu]$$

or

$$\begin{aligned} \text{Change in Length} &= \text{Longitudinal strain} \times \text{original Length} \\ &= \epsilon_1 \cdot L \end{aligned}$$

$$\text{Similarly the hoop Strain } \epsilon_2 = \frac{1}{E}(\sigma_H - \nu\sigma_L) = \frac{1}{E} \left[\frac{pd}{2t} - \nu \frac{pd}{4t} \right]$$

$$\epsilon_2 = \frac{pd}{4Et}[2-\nu]$$

In fact ϵ_2 is the hoop strain if we just go by the definition then

$$\epsilon_2 = \frac{\text{Change in diameter}}{\text{Original diameter}} = \frac{\delta d}{d}$$

where d = original diameter.

if we are interested to find out the change in diameter then

$$\text{Change in diameter} = \epsilon_2 \cdot \text{Original diameter}$$

i.e $\delta d = \epsilon_2 \cdot d$ substituting the value of ϵ_2 we get

$$\delta d = \frac{p \cdot d}{4 \cdot t \cdot E} [2-\nu] \cdot d$$

$$= \frac{p \cdot d^2}{4 \cdot t \cdot E} [2-\nu]$$

$$\text{i.e } \boxed{\delta d = \frac{p \cdot d^2}{4 \cdot t \cdot E} [2-\nu]}$$

Volumetric Strain or Change in the Internal Volume:

When the thin cylinder is subjected to the internal pressure as we have already calculated that there is a change in the cylinder dimensions i.e, longitudinal strain and hoop strains come into picture. As a result of which there will be change in capacity of the cylinder or there is a change in the volume of the cylinder hence it becomes imperative to determine the change in volume or the volumetric strain.

The capacity of a cylinder is defined as

$$V = \text{Area} \times \text{Length}$$

$$= \pi d^2/4 \times L$$

Let there be a change in dimensions occurs, when the thin cylinder is subjected to an internal pressure.

(i) The diameter **d** changes to $\delta d + d$

(ii) The length **L** changes to $\delta L + L$

Therefore, the change in volume = Final volume - Original volume

$$= \frac{\pi}{4} [d + \delta d]^2 \cdot (L + \delta L) - \frac{\pi}{4} d^2 \cdot L$$

$$\text{Volumetric strain} = \frac{\text{Change in volume}}{\text{Original volume}} = \frac{\frac{\pi}{4} [d + \delta d]^2 \cdot (L + \delta L) - \frac{\pi}{4} d^2 \cdot L}{\frac{\pi}{4} d^2 \cdot L}$$

$$\epsilon_v = \frac{\{ [d + \delta d]^2 \cdot (L + \delta L) - d^2 \cdot L \}}{d^2 \cdot L} = \frac{\{ (d^2 + \delta d^2 + 2d \cdot \delta d) \cdot (L + \delta L) - d^2 \cdot L \}}{d^2 \cdot L}$$

simplifying and neglecting the products and squares of small quantities, i.e. δd & δL

hence

$$= \frac{2d \cdot \delta d \cdot L + \delta L \cdot d^2}{d^2 L} = \frac{\delta L}{L} + 2 \cdot \frac{\delta d}{d}$$

By definition $\frac{\delta L}{L}$ = Longitudinal strain

$$\frac{\delta d}{d} = \text{hoop strain, Thus}$$

Volumetric strain = longitudinal strain + 2 x hoop strain

on substituting the value of longitudinal and hoop strains we get

$$\epsilon_1 = \frac{pd}{4tE} [1 - 2\nu] \quad \& \quad \epsilon_2 = \frac{pd}{4tE} [1 - 2\nu]$$

$$\text{or Volumetric} = \epsilon_1 + 2\epsilon_2 = \frac{pd}{4tE} [1 - 2\nu] + 2 \cdot \left(\frac{pd}{4tE} [1 - 2\nu] \right)$$

$$= \frac{pd}{4tE} \{ 1 - 2\nu + 4 - 2\nu \} = \frac{pd}{4tE} [5 - 4\nu]$$

$$\text{Volumetric Strain} = \frac{pd}{4tE} [5 - 4\nu] \quad \text{or} \quad \boxed{\epsilon_v = \frac{pd}{4tE} [5 - 4\nu]}$$

Therefore to find but the increase in capacity or volume, multiply the volumetric strain by original volume.

Hence

Change in Capacity / Volume or

$$\boxed{\text{Increase in volume} = \frac{pd}{4tE} [5 - 4\nu] V}$$

Cylindrical Vessel with Hemispherical Ends:

Let us now consider the vessel with hemispherical ends. The wall thickness of the cylindrical and hemispherical portion is different. While the internal diameter of both the portions is assumed to be equal

Let the cylindrical vassal is subjected to an internal pressure p.

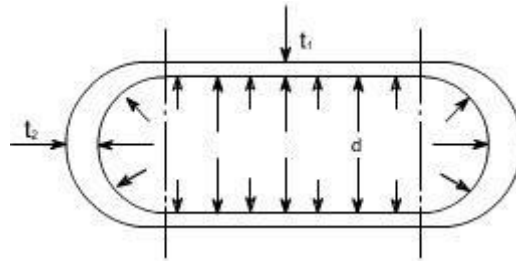

For the Cylindrical Portion

hoop or circumferential stress = σ_{HC} 'c' here signifies the cylindrical portion.

$$= \frac{pd}{2t_1}$$

longitudinal stress = σ_{LC}

$$= \frac{pd}{4t_1}$$

hoop or circumferential strain $\epsilon_2 = \frac{\sigma_{HC}}{E} - \nu \frac{\sigma_{LC}}{E} = \frac{pd}{4t_1 E} [2 - \nu]$

or
$$\epsilon_2 = \frac{pd}{4t_1 E} [2 - \nu]$$

For The Hemispherical Ends:

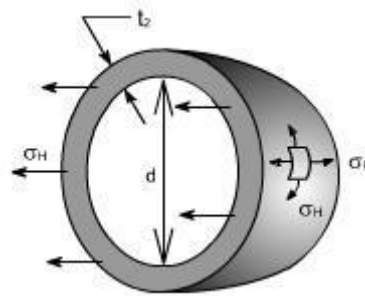

Because of the symmetry of the sphere the stresses set up owing to internal pressure will be two mutually perpendicular hoops or circumferential stresses of equal values. Again the radial stresses are neglected in comparison to the hoop stresses as with this cylinder having thickness to diameter less than 1:20.

Consider the equilibrium of the half – sphere

Force on half-sphere owing to internal pressure = pressure x projected Area

$$= p \cdot \pi d^2/4$$

Resisting force = $\sigma_H \cdot \pi \cdot d \cdot t_2$

$$\therefore p \cdot \frac{\pi \cdot d^2}{4} = \sigma_H \cdot \pi \cdot d \cdot t_2$$

$$\Rightarrow \sigma_H \text{ (for sphere)} = \frac{pd}{4t_2}$$

similarly the hoop strain = $\frac{1}{E} [\sigma_H - \nu \cdot \sigma_H] = \frac{\sigma_H}{E} [1 - \nu] = \frac{pd}{4t_2 E} [1 - \nu]$ or
$$\epsilon_{2s} = \frac{pd}{4t_2 E} [1 - \nu]$$

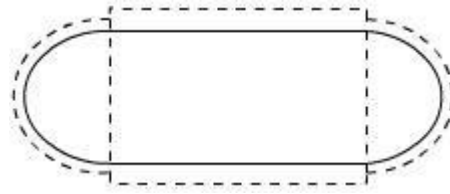

Fig – shown the (by way of dotted lines) the tendency, for the cylindrical portion and the spherical ends to expand by a different amount under the action of internal pressure. So owing to difference in stress, the two portions (i.e. cylindrical and spherical ends) expand by a different amount. This incompatibility of deformations causes a local bending and shearing stresses in the neighbourhood of the joint. Since there must be physical continuity between the ends and the cylindrical portion, for this reason, properly curved ends must be used for pressure vessels.

Thus equating the two strains in order that there shall be no distortion of the junction

$$\frac{pd}{4t_1E}[2 - \nu] = \frac{pd}{4t_2E}[1 - \nu] \quad \text{or} \quad \frac{t_2}{t_1} = \frac{1 - \nu}{2 - \nu}$$

But for general steel works $\nu = 0.3$, therefore, the thickness ratios becomes

$$t_2 / t_1 = 0.7/1.7 \text{ or}$$

$$\boxed{t_1 = 2.4 t_2}$$

i.e. the thickness of the cylinder walls must be approximately 2.4 times that of the hemispheroid ends for no distortion of the junction to occur.

SUMMARY OF THE RESULTS : Let us summarise the derived results

(A) The stresses set up in the walls of a thin cylinder owing to an internal pressure p are :

(i) Circumferential or hoop stress

$$\sigma_H = pd/2t$$

(ii) Longitudinal or axial stress

$$\sigma_L = pd/4t$$

Where d is the internal diameter and t is the wall thickness of the cylinder.

then

$$\text{Longitudinal strain } e_L = 1/E [\sigma_L - \nu\sigma_H]$$

$$\text{Hoop strain } e_H = 1/E [\sigma_H - \nu\sigma_L]$$

(B) Change of internal volume of cylinder under pressure

$$= \frac{pd}{4tE}[5 - 4\nu]V$$

(C) For thin spheres circumferential or hoop stress

$$\sigma_H = \frac{pd}{4t}$$

Thin rotating ring or cylinder

Consider a thin ring or cylinder as shown in Fig below subjected to a radial internal pressure p caused by the centrifugal effect of its own mass when rotating. The centrifugal effect on a unit length of the circumference is

$$p = m \omega^2 r$$

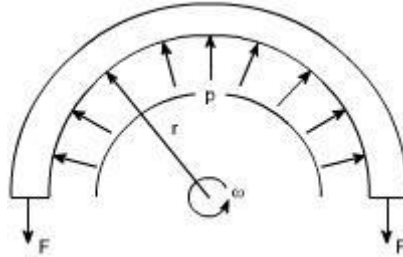

Fig 19.1: Thin ring rotating with constant angular velocity ω

Here the radial pressure 'p' is acting per unit length and is caused by the centrifugal effect of its own mass when rotating.

Thus considering the equilibrium of half the ring shown in the figure,

$$2F = p \times 2r \text{ (assuming unit length), as } 2r \text{ is the projected area}$$

$$F = pr$$

Where F is the hoop tension set up owing to rotation.

The cylinder wall is assumed to be so thin that the centrifugal effect can be assumed constant across the wall thickness.

$$F = \text{mass} \times \text{acceleration} = m \omega^2 r \times r$$

This tension is transmitted through the complete circumference and therefore is resisted by the complete cross – sectional area.

$$\text{Hoop stress} = F/A = m \omega^2 r^2 / A$$

Where A is the cross – sectional area of the ring.

Now with unit length assumed m/A is the mass of the material per unit volume, i.e. the density ρ .

$$\text{hoop stress} = \rho \omega^2 r^2$$

$$\sigma_H = \rho \cdot \omega^2 \cdot r^2$$